

Smart Card Installation and Configuration Guide for Xerox® AltaLink® / Versalink® Series

Version 1.0

March 25, 2024

2024 Xerox Corporation. All rights reserved. Xerox®, Xerox and Design®, AltaLink®, VersaLink®, WorkCentre®, FreeFlow®, SMARTsend®, Scan to PC Desktop®, MeterAssistant®, SuppliesAssistant®, Xerox Secure Access Unified ID System®, Xerox Extensible Interface Platform®, Global Print Driver®, and Mobile Express Driver® are trademarks of Xerox Corporation in the United States and/or other countries. BR40083

Adobe®, Adobe PDF logo, Adobe® Reader®, Adobe® Type Manager®, ATM™, Flash®, Macromedia®, Photoshop®, and PostScript® are trademarks or registered trademarks of Adobe Systems, Inc. Apple®, Bonjour®, EtherTalk™, TrueType®, iPad®, iPhone®, iPod®, iPod touch®, AirPrint® and the AirPrint Logo®, Mac®, Mac OS®, and Macintosh® are trademarks or registered trademarks of Apple Inc. in the U.S. and other countries. HP-GL®, HP-UX®, and PCL® are registered trademarks of Hewlett-Packard Corporation in the United States and/or other countries.

Microsoft®, Windows Vista®, Windows®, Windows Server®, and OneDrive® are registered trademarks of Microsoft Corporation in the United States and other countries.

Wi-Fi CERTIFIED Wi-Fi Direct® is a trademark of the Wi-Fi Alliance

1.	Introduction	1-3
	Supported Printers.....	1-3
	Minimum software levels	1-4
2.	Smart Card Feature Overview	2-5
	Authentication	2-5
	Hold All jobs.....	2-5
	Email Signing and encryption	2-5
	supported card readers.....	2-6
	supported card types	2-6
3.	Documentation and Support	3-1
4.	Preparation	4-2
	Preparation overview	4-2
	configuration checklist	4-2
5.	Installation	5-1
	installation overview.....	5-1
	Hardware Installation	5-1
	connect usb smart card reader to the printer	5-1
	Software Configuration	5-4
	Accessing Administration and configuration settings	5-4
	enter the smart card enablement key	5-4
	Configuring the Smart Card.....	5-7
	configure smart card authentication	5-7
	enable NTP service	5-9
	configure alternate authentication	5-11
	certificate validation	5-12
	import a certificate authority certificate	5-13
	install a domain controller certificate	5-15
	configure transport layer security	5-16
	configure Certificate Validation Information.....	5-18
	configure smart card inactivity timer	5-20
	configure acquiring logged-in email addresses for users.....	5-21
	configure smtp email settings	5-24
	configure smtp authentication.....	5-26
	configure connection encryption.....	5-27

	configure file size management	5-28
	test configuration	5-29
	configure general email settings	5-30
	configure address books	5-32
	configure email defaults	5-33
	configure email compression	5-33
	configure email security	5-34
6.	Printing Features	6-40
	configure hold all jobs	6-40
	configure secure print driver defaults	6-41
	configuring the print driver	6-43
7.	Confirm the Installation	7-1
	using the smart card	7-1
8.	Troubleshooting	8-2
	fault clearance	8-2
	locating the serial number	8-2
	troubleshooting tips	8-3
	during installation	8-3
	after installation	8-3
9.	Additional Information and Resources	9-1
	Security @ Xerox®	9-1
	Responses to Known Vulnerabilities	9-1
	Additional Resources	9-1

1. Introduction

The Smart Card solution brings an advanced level of security to sensitive information. Organizations can restrict access to the walk-up features of a Xerox® multifunction printer. This practice ensures that only authorized users can print, copy, scan, email, and fax information.

After validation, you are logged in to the Xerox® printer for all walk-up features. For added security, the functions are tracked. This guide explains how to install and configure the Smart Card solution. The guide identifies the resources and equipment required for a successful installation.

Note: Depending on the printer model and software version you are using, the configuration instructions can vary.

For more information, contact your local Xerox Representative

SUPPORTED PRINTERS

Xerox® VersaLink® B625 (Mono MFP) and C625 (Color MFP) are very similar and consist of an input document handler and scanner, marking engine, controller, and user interface. A typical configuration is depicted below. Please note that options including finishers, paper trays, document handlers, etc. may vary configuration, however, they are not relevant to security and are not discussed.

- Xerox® AltaLink® Series B8045/8055/8065/8075/8090 Multifunction Printers
- Xerox® AltaLink® Series C8030/8035/8045/8055/8070 Multifunction Printers
- Xerox® AltaLink® B8145/B8155/B8170 Multifunction Printers
- Xerox® AltaLink® C8130/C8135/C8145/C8155/C8170 Multifunction Printers
- Xerox® WorkCentre® EC7856/7836 Multifunction Printers
- XeroxVersaLink® B415 Multifunction Printers
- XeroxVersaLink® B625 Multifunction Printers
- XeroxVersaLink® C415 Multifunction Printers
- XeroxVersaLink® C625 Multifunction Printers

MINIMUM SOFTWARE LEVELS

Xerox® Printer	Minimum Printer Software Version
Xerox® AltaLink® B8045/8055/8065/8075/8090 Multifunction Printer	100.008.037.03831
Xerox® AltaLink® C8030/8035/8045/8055/8070 Multifunction Printer	100.xxx.037.03830
Xerox® AltaLink® B8145/B8155/B8170 Multifunction Printer	105.xxx.009.34422
Xerox® AltaLink® C8130/C8135/C8145/C8155/ C8170 Multifunction Printer	105.xxx.009.34422
Xerox® WorkCentre® EC7856/7836 Multifunction Printer	073.xxx.167.17200
XeroxVersaLink® B415 Multifunction Printers	119.029.003.11705
XeroxVersaLink® B625 Multifunction Printers	119.025.003.11705
XeroxVersaLink® C415 Multifunction Printers	119.028.003.11705
XeroxVersaLink® C625 Multifunction Printers	119.024.003.11705

To identify the software version on your printer, at the control panel, touch Device, then touch About. The software version number appears

2. Smart Card Feature Overview

AUTHENTICATION

Xerox offers the Smart Card authentication feature. This authentication enables users who possess smart cards to use the card for network authentication at the multifunction printer. Smart cards contain user identity certificates and public and private keys. This certificate enables the multifunction printer to perform a Kerberos authentication to the Windows active domain controller that issued the identity certificate. The Smart Card feature was developed to support smart cards and has been extended to support PIV, CAC, Gemalto IDPrime MD, and other smart cards. This document describes the configuration settings for these smart cards. The multifunction printer determines automatically which type of smart card is inserted in the card reader. The multifunction printer uses the appropriate software libraries to communicate with the specific card. Authentication settings are configured on the multifunction printer, according to the network infrastructure.

HOLD ALL JOBS

The Xerox Hold All Jobs feature ensures that jobs are held securely at the multifunction printer. Jobs are available for release only after you authenticate at the printer. The printer holds the jobs for a specified time until they are released. It is not necessary to enter a Secure Print PIN to use this feature. To use the Hold All Jobs feature, configure the print driver to pull the username alias from the Smart Card certificate or Windows operating system. Refer to [Configure the Print Driver](#). This feature provides the following benefits:

- Banner Pages are not required to separate jobs, which reduces waste.
- You can manage your held jobs more efficiently. You can select only the jobs that you want to print and delete older versions of documents that you no longer want to print.
- Confidential jobs are held in the queue for the owner to release them, rather than the documents waiting in the output tray to be picked up.

EMAIL SIGNING AND ENCRYPTION

With Smart Card authentication, the multifunction printer has full access to the public and private keys of the user. The printer can use these keys to sign and encrypt emails.

You can sign an email payload through the Smart Card with your private key. This action enables other users to validate the signature with your public key, which they can obtain from you or from LDAP. This validation assures the recipient that the content is original and was not compromised in transit.

You can encrypt an email payload with your public key through the Smart Card or LDAP, then send the encrypted email to the user. This option offers the benefit that, while in transit through the infrastructure, no one can decipher the contents of the email. After the email is in your Inbox, you can decrypt the email with your private key, making the payload readable again.

SUPPORTED CARD READERS

The customer is responsible for providing a card reader for each Xerox® multifunction printer. Most Chip Card Interface Device (CCID)-compliant card readers can be used, but not all card readers are validated. It is recommended that you use the Indentive SCR3310 v2.0 smart card reader.

SUPPORTED CARD TYPES

Customers are responsible for purchasing and configuring the access cards. The following card types are supported:

- CAC
- PIV
- Gemalto IDPrime MD

Other card types function with the Smart Card solution, but they are not validated.

3. Documentation and Support

For information about your Xerox® multifunction printer, the following resources are available:

- A System Administrator Guide provides detailed instructions and information about connecting your printer to the network and installing optional features. This guide is intended for system administrators.
- A User Guide provides detailed information about all the features and functions on your printer. This guide is intended for general users.

Most answers to your questions are provided by the support documentation supplied for your printer. Alternatively, you can contact Xerox Technical Support or access the Xerox website at www.xerox.com User Data Protection While Within Product

4. Preparation

PREPARATION OVERVIEW

This section explains the preparation and resources required to install the Smart Card feature.

CONFIGURATION CHECKLIST

Summary	Status
1. Obtain the IP address or host name for each applicable Windows domain controller.	
2. If domain controller certificate validation is required, obtain the certificate for each applicable domain controller, including all intermediate certificates up to the root certificate. Note: Typically, this procedure is required only for the Smart Card solution.	
3. If Online Certificate Status Protocol (OCSP) is available, obtain the IP address or host name for the OCSP server.	
4. If a software upgrade is required, obtain and install the required software release.	
5. Mount the Smart Card Reader to the multifunction printer, then connect the USB cable to one of the rear ports. Refer to Connect the USB Smart Card Reader to the Multifunction Printer .	
6. Install the Smart Card software feature enablement key. Refer to Enter the Smart Card Enablement Key .	
7. Configure Smart Card authentication, the optional NTP, and the optional Alternate Control Panel Login. Refer to Configuring the Smart Card .	
8. Install any required certificates, then configure the validation settings. Refer to Configure a Security Certificate .	
9. Configure the multifunction printer LDAP settings. Refer to Configure Acquiring Logged-In User's Email Address .	
10. Configure the multifunction printer SMTP email, signing and encryption settings. Refer to Configure SMTP (Email) Settings .	
11. Configure the Hold All Jobs and Secure Print policies, if necessary. Refer to Printing Features .	

5. Installation

INSTALLATION OVERVIEW

This section provides instructions for installing and configuring the Smart Card solution. There are four main installation procedures to follow in the sequence given:

1. **Hardware Installation:** Unpack the Smart Card Enablement kit, then install the card reader device.
2. **Enabling the Smart Card:** To enable the Smart Card for configuration, use the feature enable key.
3. **Configuring the Smart Card:** Enable the Smart Card function, then customize the settings.
4. **Using the Smart Card:** For instructions on how to use the card reader to access the printer functions, refer to Using the Smart Card.

Note: Depending on the printer model and software version you are using, the configuration instructions can vary.

Hardware Installation

CONNECT USB SMART CARD READER TO THE PRINTER

To install the card reader:

1. Unpack the Smart Card Enablement Kit (CAC/PIV). The kit contains the following items:
 - Smart Card Enablement Guide (CAC/PIV)
 - Card Reader SCR3310v2
 - Four Velcro® dual-lock fastener pads
 - Two cable ties
 - One ferrite bead
 - Five cable clamps

Before you install the hardware, ensure that you have read the license agreement and agree to the terms and conditions.

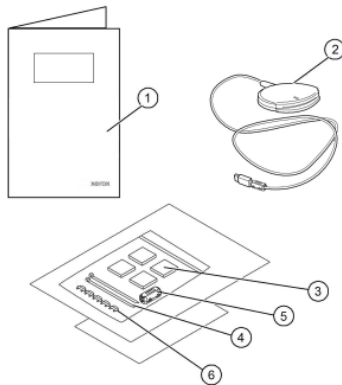

2. Locate the card reader device, then install and configure the device.

Note: The system administrator configures the cards before the card reader is installed on the printer.

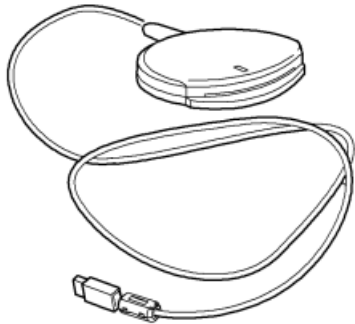

3. Attach the ferrite bead to the reader cable. Note: Clip the ferrite bead onto the cable that is behind the connector.

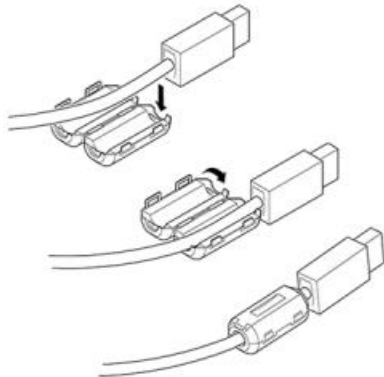

4. Attach the dual-lock fastener pads to the card reader device. Fasteners are provided to secure the card reader to the multifunction printer.
 - Peel back the fastener pad backing strip, then position the fastener pad on the under-side of the card reader, as shown.
 - Repeat these steps for each of the fastener pads supplied.]

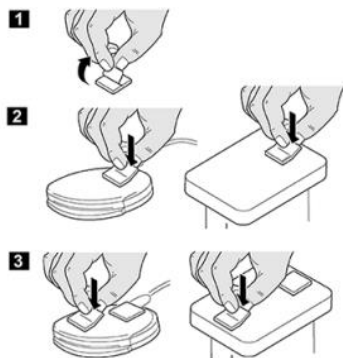

5. When all the dual-lock fastener pads are attached to the card reader, remove the backing strips on each of the pads.

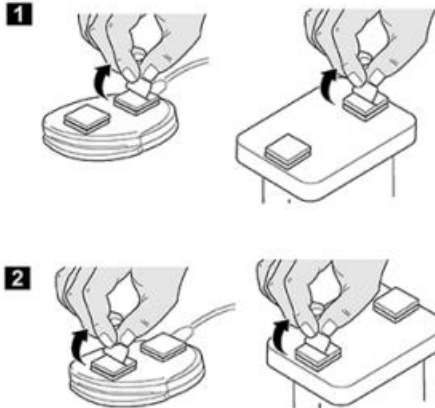

6. Place the card reader on the multifunction printer.
 - Gently place the card reader on the printer. Do not fix the card reader in place at this time.
 - Position the card reader in a suitable location. Ensure that the card reader does not obstruct any access points or the opening of doors or covers.
 - Verify that the cable has sufficient length to connect to the rear of the network controller.
 - When the card reader is in a suitable location, to fix the card reader device in place, press firmly on the reader.
7. Connect the card reader to the multifunction printer.
 - Insert the USB connection into the slot provided on the rear of the network controller.
 - Use the cable clamps and cable ties provided to bundle the cables and ensure that the cabling is neat.

The hardware installation is now complete.

Software Configuration

ACCESSING ADMINISTRATION AND CONFIGURATION SETTINGS

The Embedded Web Server is the administration and configuration software installed on the printer. This software allows you to configure and administer the printer from a Web browser.

The administrator password is required to access locked settings in the Embedded Web Server or at the control panel. Most printer models have a default configuration that restricts access to some settings. In the Embedded Web Server, you can restrict access for settings on the Properties tab. At the device touch screen, you can restrict settings in the Tools menu.

To access the Embedded Web Server and log in as the administrator:

1. At your computer, open a Web browser.
2. In the URL address field, type `http://` followed by the IP Address of the multifunction printer. For example: If the IP Address is 192.168.100.100, type the following into the URL address field: `http://192.168.100.100`. Press Enter or Return.
3. In the top-right area of the page, click Login.
 - a. For User ID, type admin.
 - b. For Password, type the administrator password. The default administrator password is the printer serial number. You can obtain the serial number from inside the front door of the printer, from the configuration report, and from the home page of the Embedded Web Server. The password is case-sensitive.
4. Click Login.

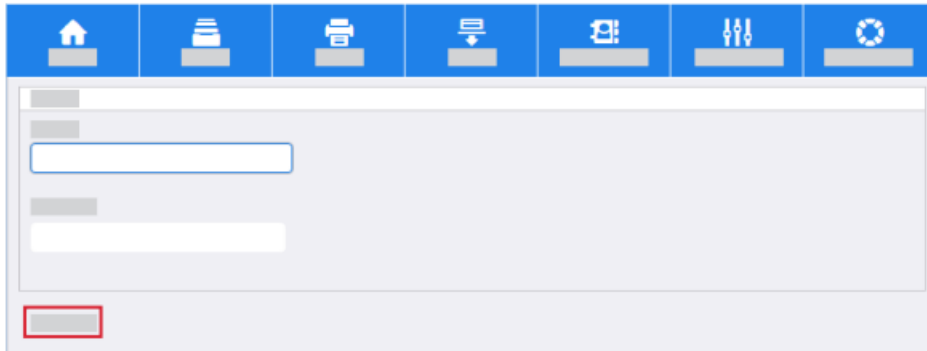

For more information about accessing and configuring the Embedded Web Server settings, refer to the System Administrator Guide for your Xerox multifunction printer.

ENTER THE SMART CARD ENABLEMENT KEY

Before you configure the Smart Card solution, use the Embedded Web Server to enable the Smart Card feature on your multifunction printer. The Feature Enablement Key is printed on the inside cover of the enablement guide provided within the Smart Card (CAC/PIV) kit.

To enable the device software:

1. Access the Embedded Web Server, then click the Properties tab. For more information, refer to [Accessing Administration and Configuration Settings](#).

2. Click the Login/Permissions/Accounting link.
3. Click the Login Methods link.
4. Click the Control Panel Login button.
 - a. From the Control Panel Login menu, select Smart Cards.

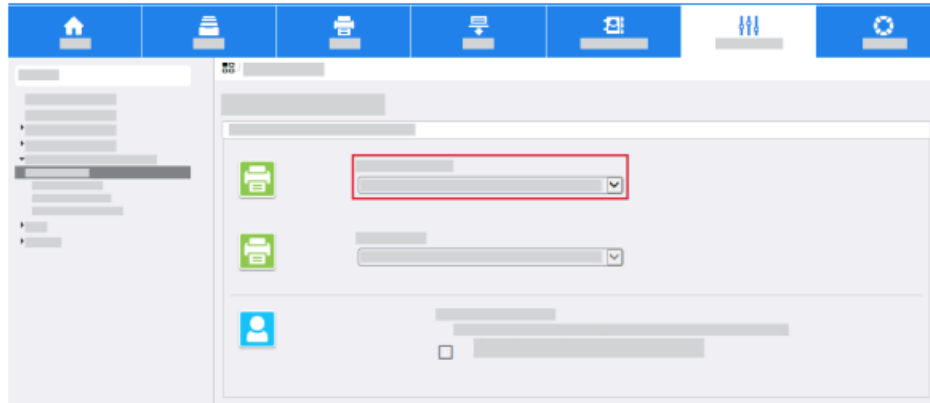

- b. If users need an alternate method of authentication, from the Alternate Control Panel Login menu, select User Name/Password — Validate on the Network.

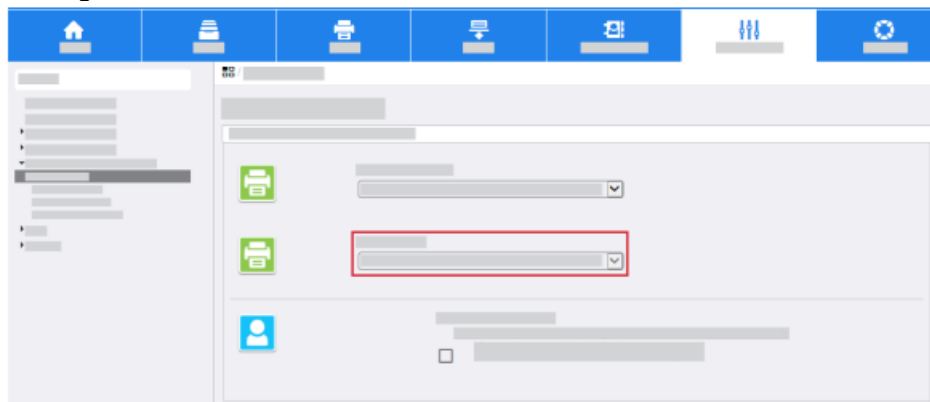

- c. If the device uses the email address registered to the authenticated user, select the check box for Personalized User Profile

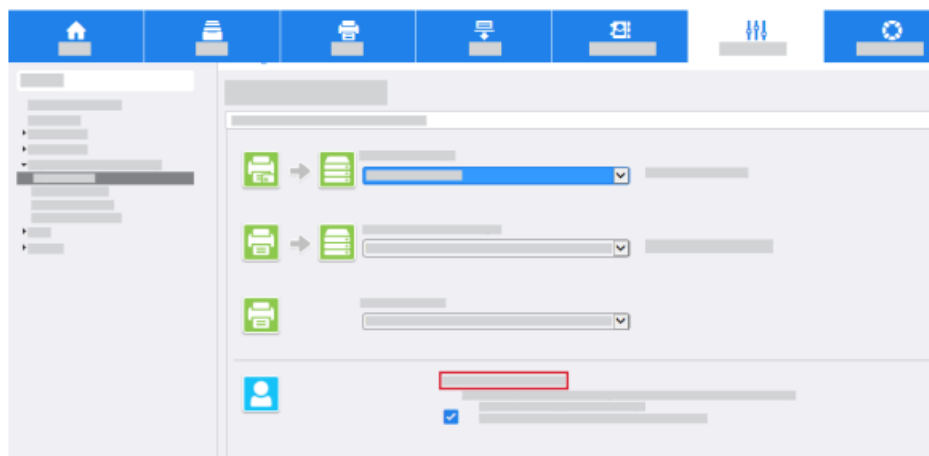

d. Click save.

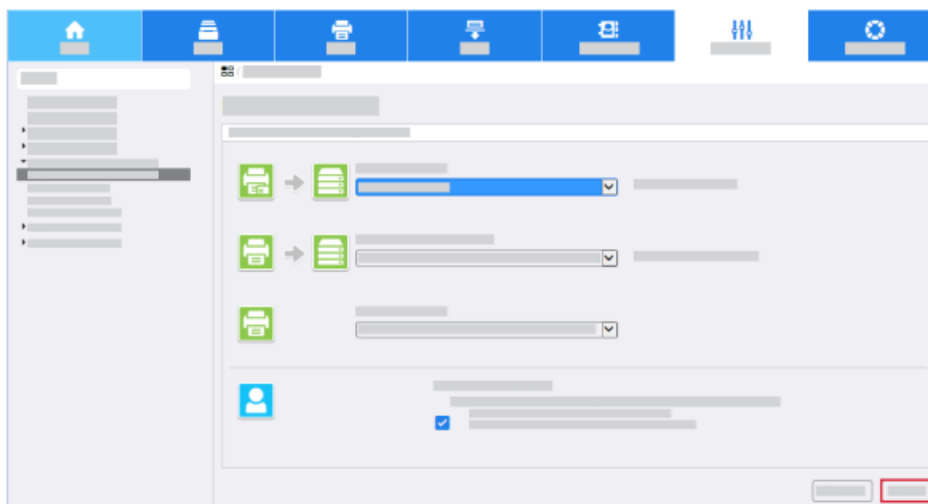

5. In the Smart Card Enablement area, enter the unique Feature Enablement Key provided on the inside cover of the Smart Card Enablement (CAC/PIV) Guide.

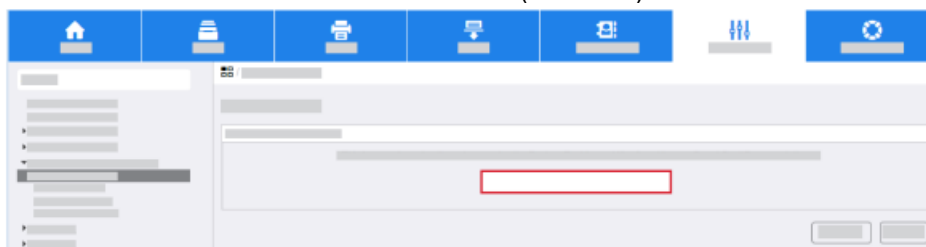

6. Click Next.
A confirmation message appears.

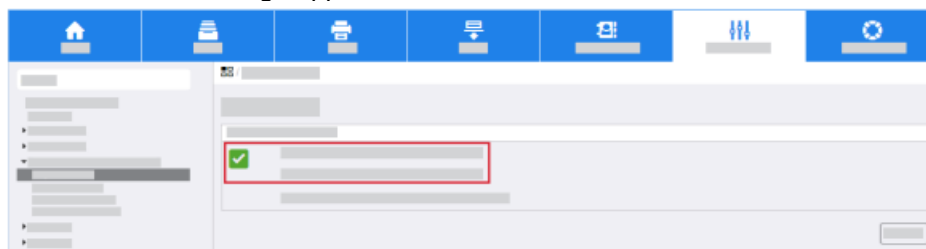

7. Click Next. The Smart Card settings are now ready to configure.

Note: No services are restricted until the Smart Card is configured fully through the Embedded Web Server

Configuring the Smart Card

After the Smart Card feature is enabled on the multifunction printer, you can use the Embedded Web Server to configure the smart card.

CONFIGURE SMART CARD AUTHENTICATION

To enable and configure the Smart Card:

1. Access the Embedded Web Server, then click the Properties tab. For more information, refer to Accessing Administration and Configuration Settings.
2. Click the Login/Permissions/Accounting link, then click Login Methods.
3. For Domain Controller, enter the details for the authentication server.
 - a. From the Configuration Settings list, for Domain Controllers, click Edit.

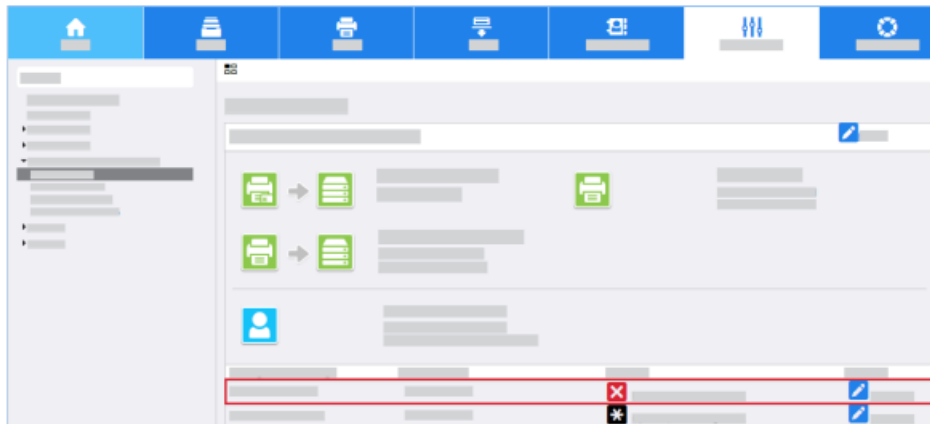

Note: Initially, the domain controllers are empty and the NTP server is not set.

- b. Click Add Domain Controller.

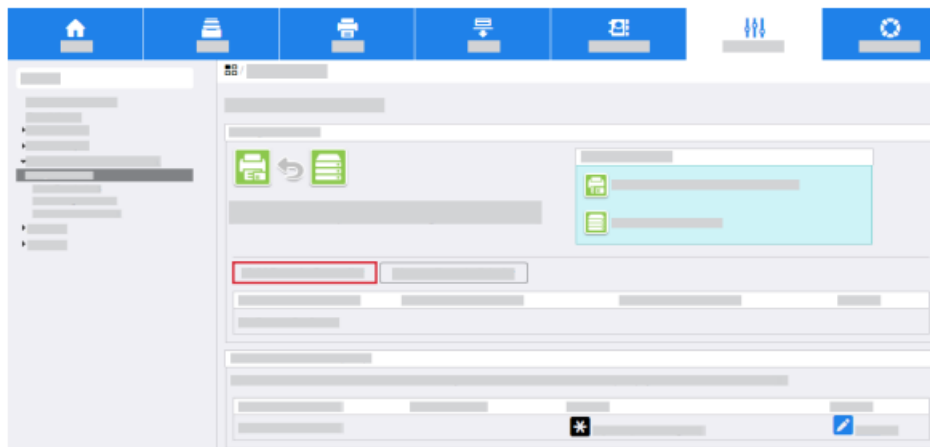

- c. Select the check box for Windows Based Domain Controller. Or, to select the Linux-Based Domain Controller, clear the check box.
- d. Select the IP Address or the fully qualified host name, then enter the domain controller details.

- e. Unless your Kerberos Port is different, ensure that Port 88 is selected.

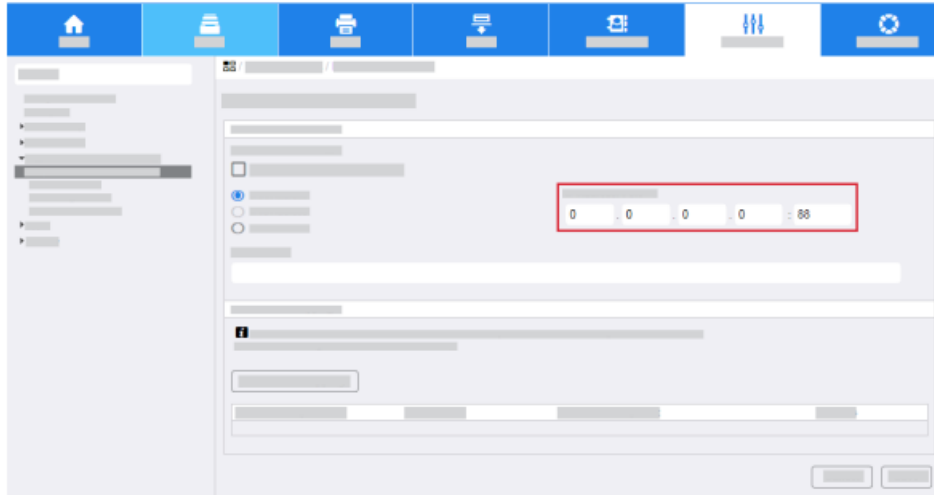

- f. For the Domain Name field, enter the fully qualified domain name. g. Click Save.

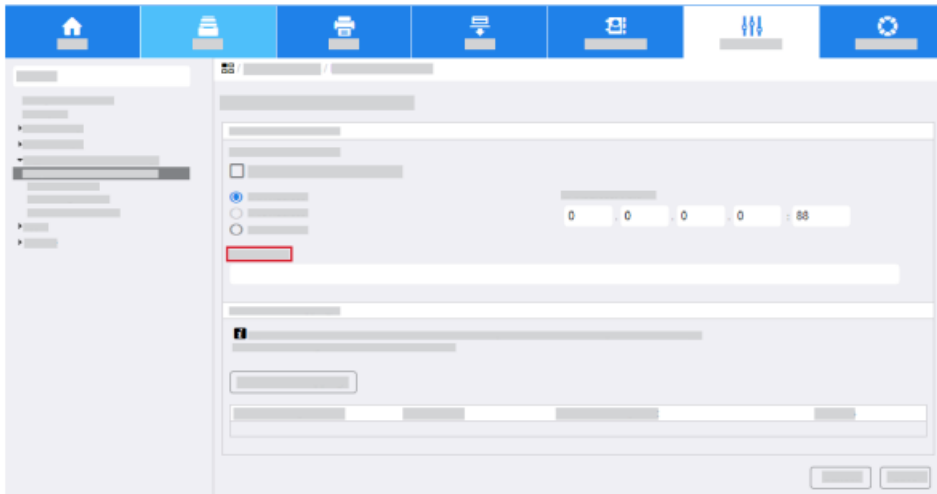

- g. Click Save.

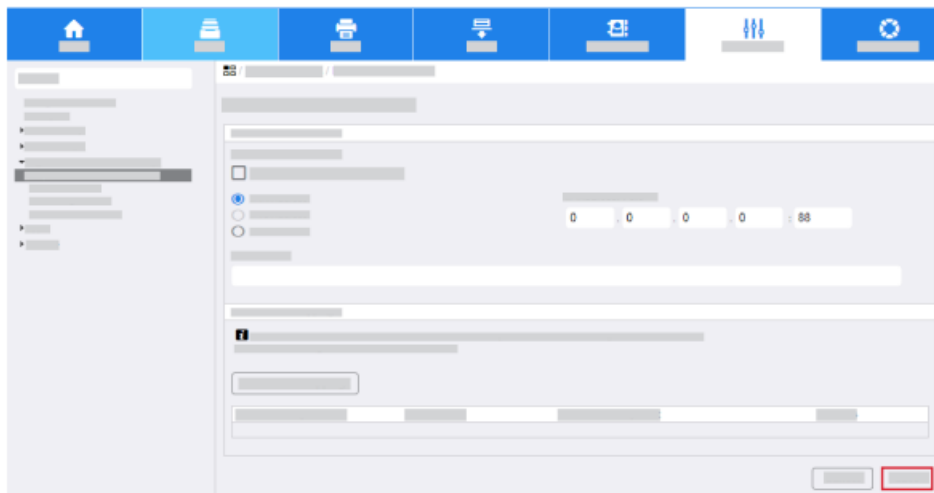

ENABLE NTP SERVICE

To configure the date and time to update automatically:

1. From the Configuration Settings list, for Network Time Protocol, click Edit.

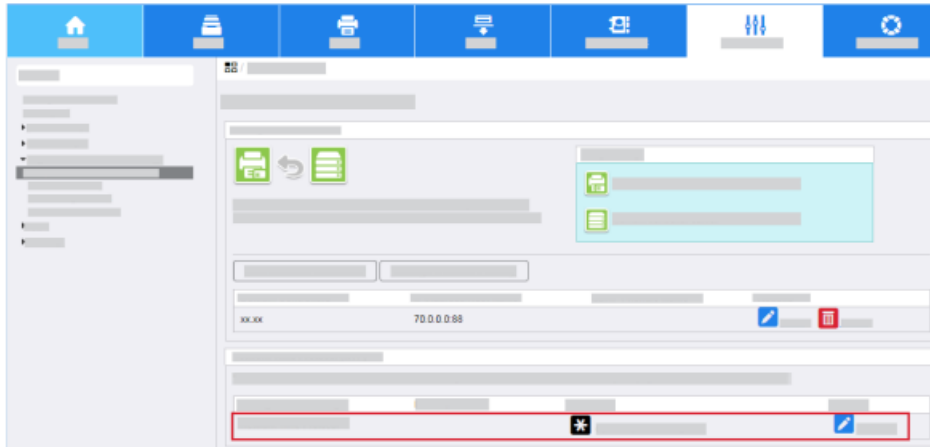

- a. To enable NTP, select the check box for Enabled.

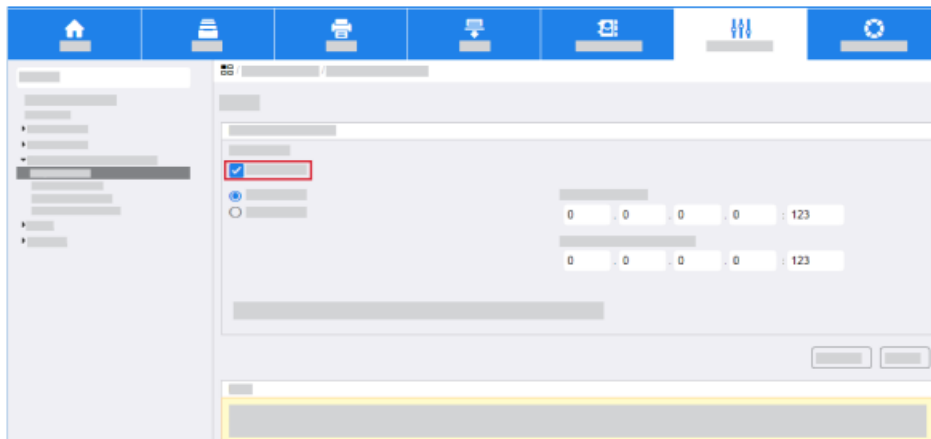

- b. Enter the IP address or host name for the primary and alternate time server. Often this address is the same address as the domain controller.

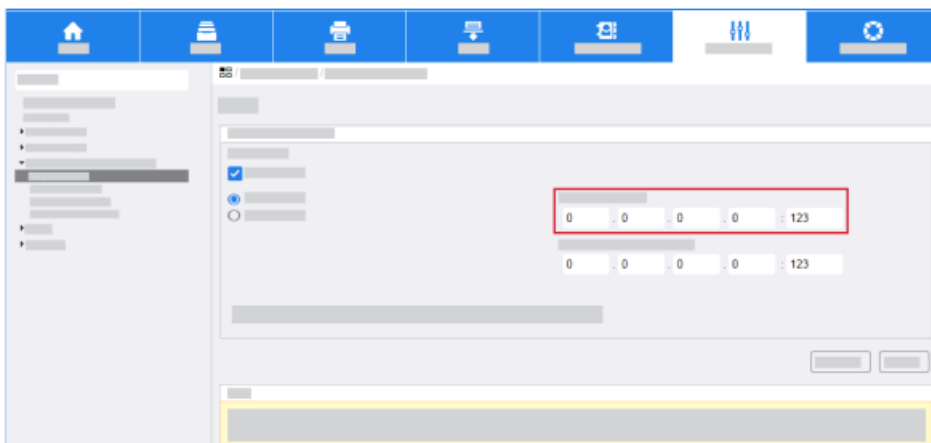

c. Click Save.

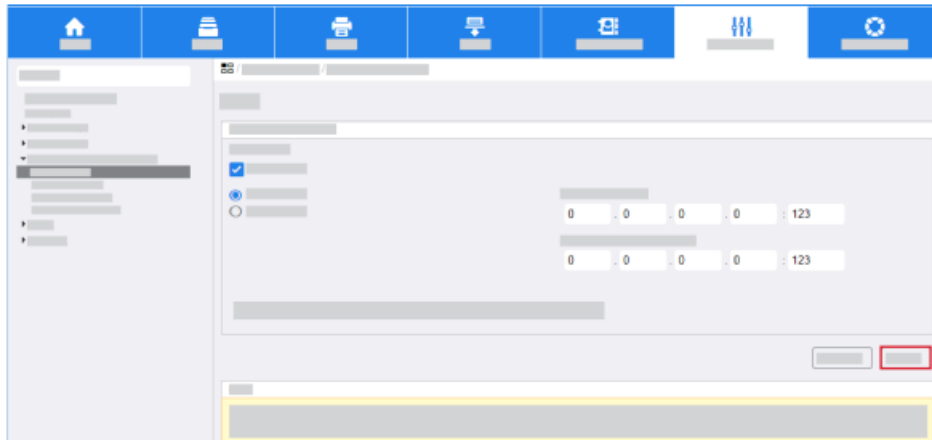

2. View the Summary screen and ensure that all settings are correct.

3. Click Close.

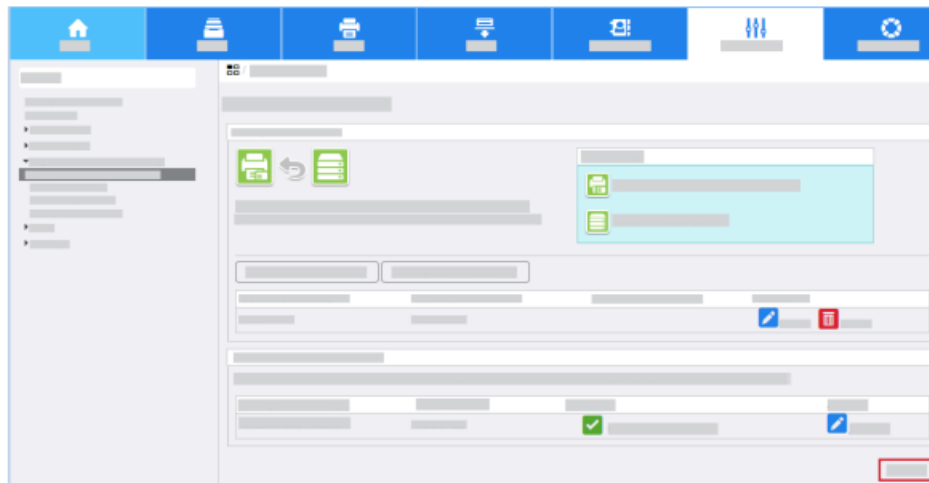

CONFIGURE ALTERNATE AUTHENTICATION

If Alternate Authentication is not required, refer to Configure a Security Certificate.

If Alternate Authentication is enabled, configure the authentication server.

1. In the Configuration Settings list, for Authentication Servers / Control Panel (Alternate), click Edit.

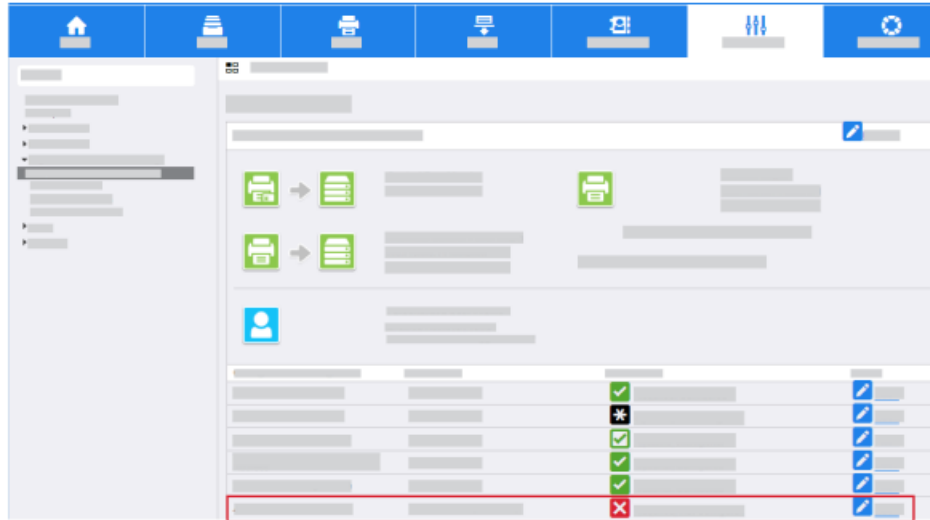

- a. From the Authentication Type menu, select Kerberos.
- b. Click Add New.

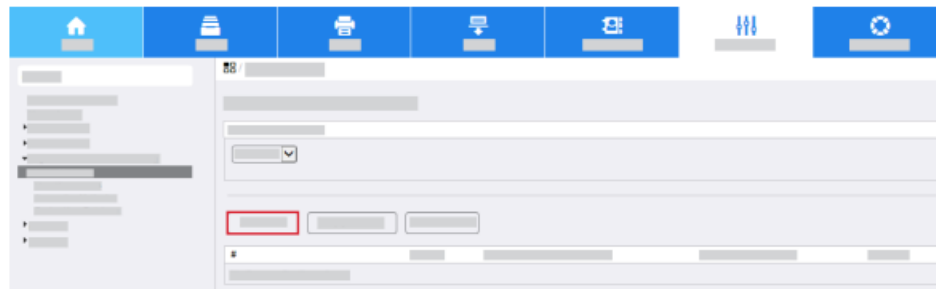

- c. Enter the required domain or realm details.

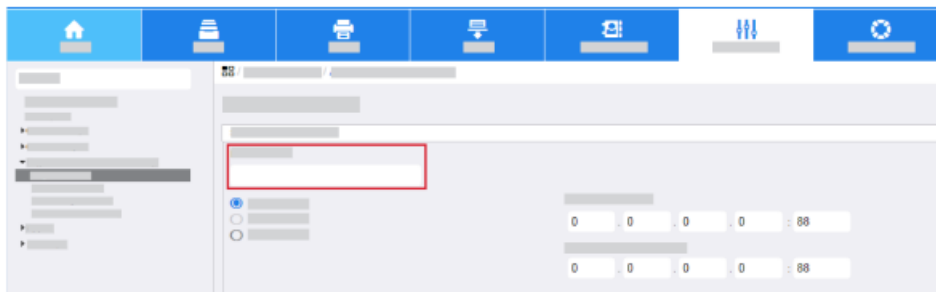

- d. Select the IP Address or the host name, then enter the server details. For most installations, the Alternate Authentication server is the same as the Smart Card domain controller.

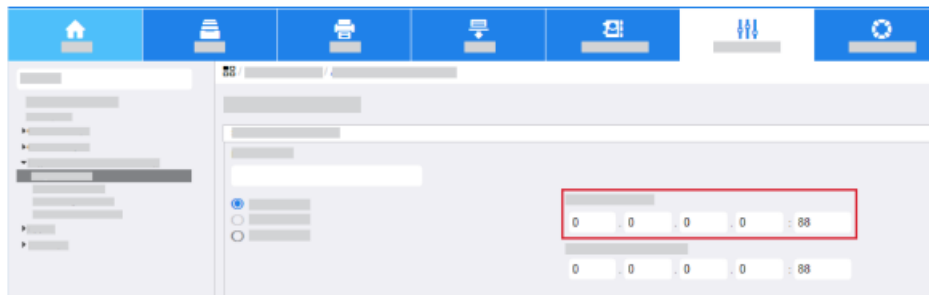

2. Click Save.
3. Click Close

CERTIFICATE VALIDATION

When you use certificate validation, one of the following options is required:

Note: The Online Certificate Status Protocol (OCSP) is an Internet protocol used for obtaining the revocation status of an X.509 digital certificate.

- Validate the certificate returned from the domain controller server against the OCSP server.

Note: Ensure that the OCSP signed certificate and its issuing CA chain of trust is imported.

- Validate the domain controller certificate stored on the Xerox machine against the OCSP server.

Note: Ensure that the OCSP signed certificate and its issuing CA chain of trust is imported and that the domain controller certificate is imported.

- Validate the email encryption certificate from the smart card against the OCSP server.

Note: Ensure that the OCSP signed certificate and its issuing CA chain of trust is imported.

- Validate if that the domain controller certificate returned by the domain controller server matches the domain controller certificate stored on the Xerox machine.

Note: Ensure that the domain controller certificate is imported. If the multifunction printer requires certificate validation, perform the instructions in these sections:

- [Import a Certificate Authority Certificate](#)
- [Install a Domain Controller Certificate](#)

If certificate validation is not required, refer to [Configure Smart Card Inactivity Timer Operational Security](#).

IMPORT A CERTIFICATE AUTHORITY CERTIFICATE

To import a certificate from the Certificate Authority, perform the following steps:

1. Click the Properties tab, then click the Security link.
2. Click Certificates→Security Certificates.
 - a. Click the Root/Intermediate Trusted Certificates tab.

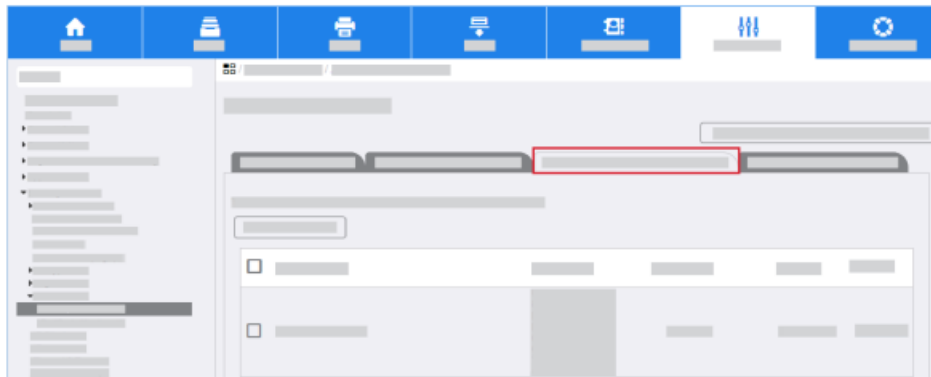

- b. Click Install Certificate.

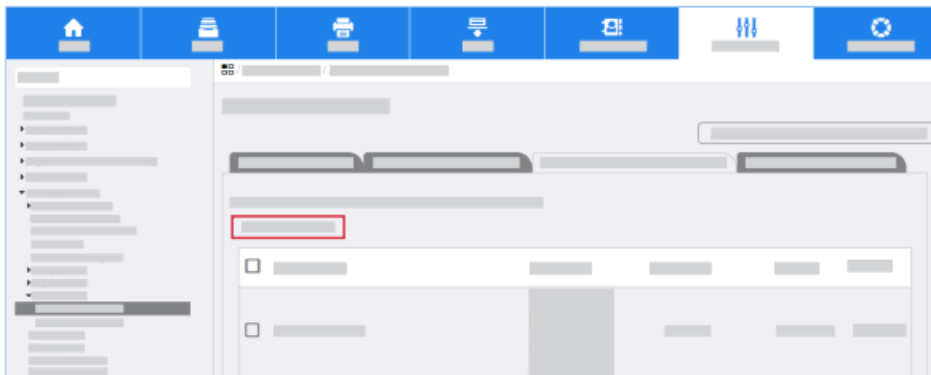

- c. Click Browse, then navigate to your certificate authority certificates.

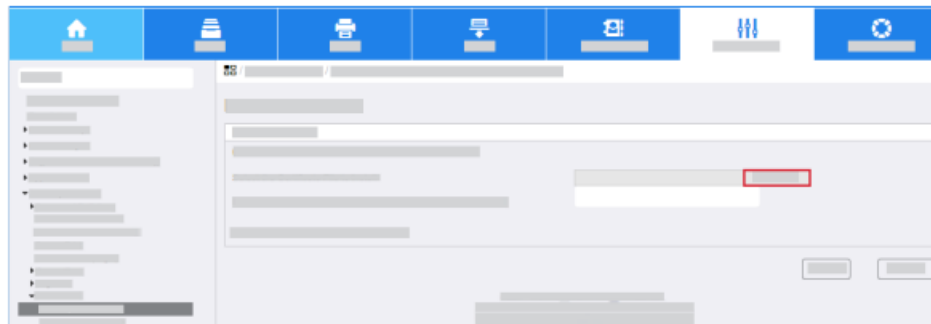

- d. Select the certificate required, then click Open.
- e. If the certificate is encrypted, on the Password Required screen, enter the password.

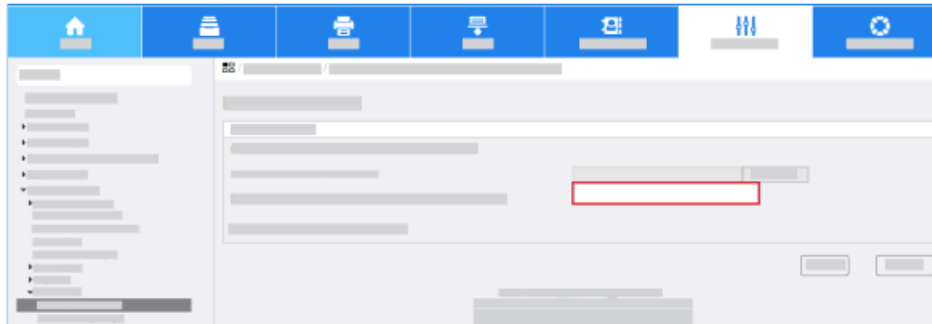

- f. To install the certificate, click Next.

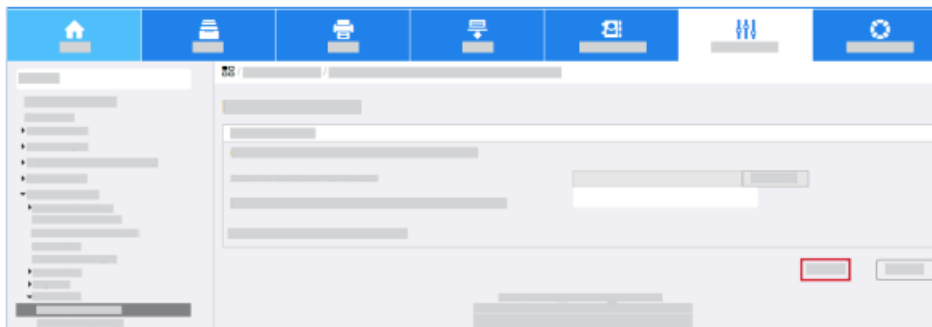

Note: Import both the Root CA and the Intermediate CA certificates to the multifunction printer. This action establishes a chain of trust for certificates on individual smart cards.

3. Click Next.
4. When you configure security certificates on the printer, TLS provides a secure connection between your computer and the multifunction printer. To configure TLS, refer to [Configure TLS](#).

INSTALL A DOMAIN CONTROLLER CERTIFICATE

To install a domain controller certificate, perform the following steps:

1. Click the Properties tab, then click the Security link.
2. Click Certificates→Security Certificates.
 - a. Click the Domain Controller Certificates tab.

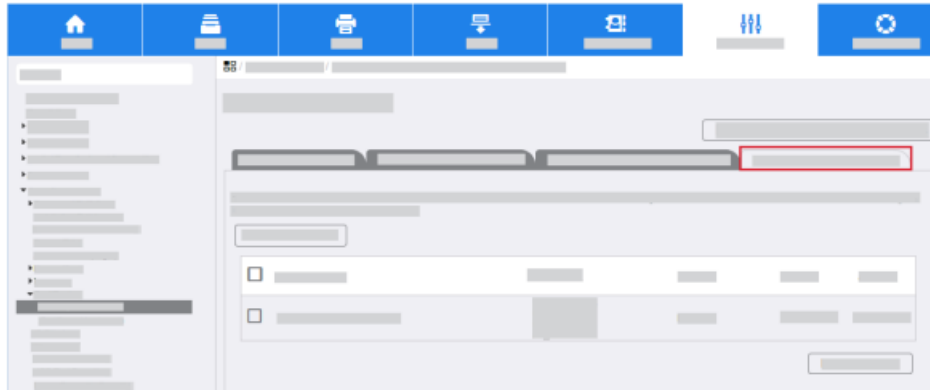

- b. Click Install Certificate.

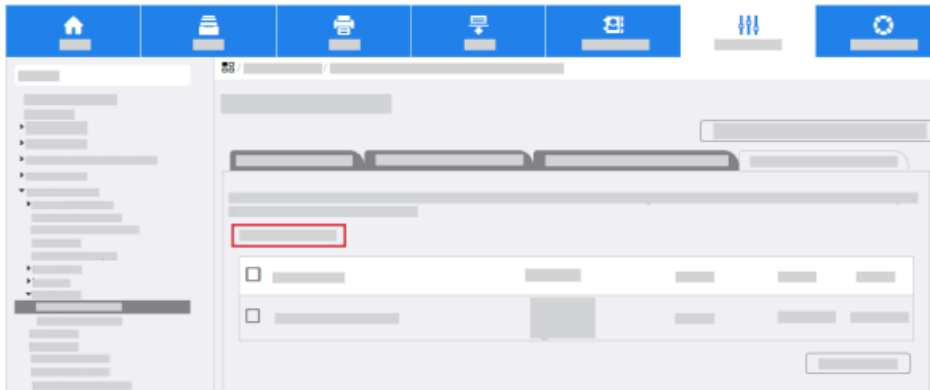

- c. Click Browse, then navigate to the domain controller certificates.

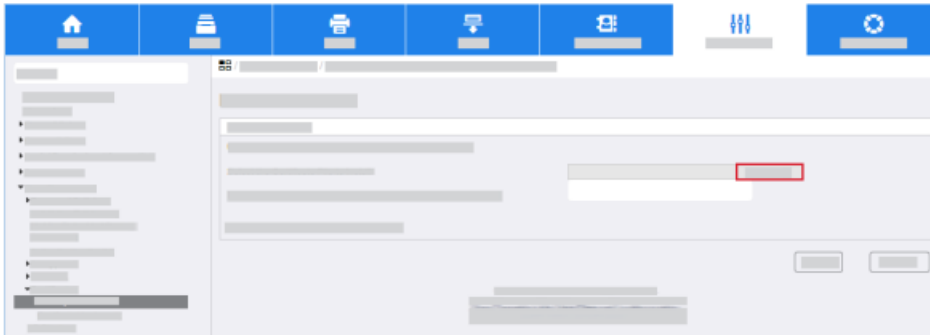

- d. Select the certificate required, then click Open.
- e. If the certificate is encrypted, enter the password.

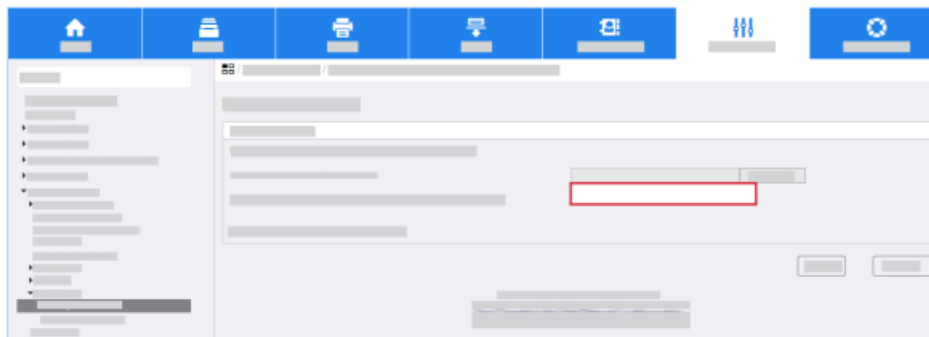

- f. To install the certificate, click Next.

3. Repeat the process until you have uploaded all the required certificates.

CONFIGURE TRANSPORT LAYER SECURITY

When you configure security certificates on the printer, Transport Layer Security (TLS) provides a secure connection between your computer and the multifunction printer. TLS is enabled on the printer automatically. If you do not want to configure TLS, proceed to [Configure Certificate Validation](#).

To configure TLS, perform the following steps:

1. Click the Properties tab, then click the Connectivity link.
2. Click Setup.
 - a. From the Protocol settings list, for HTTP, click Edit.

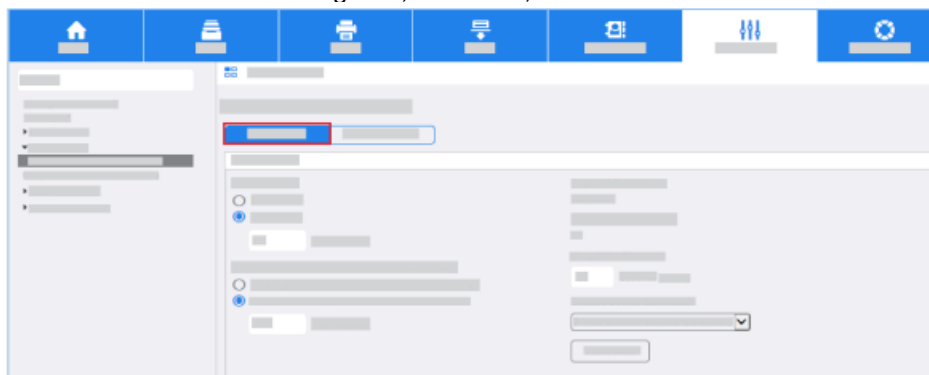

- b. If you want to force traffic over a secure connection, such as HTTPS, click Yes (All HTTP requests are switched to HTTPS)

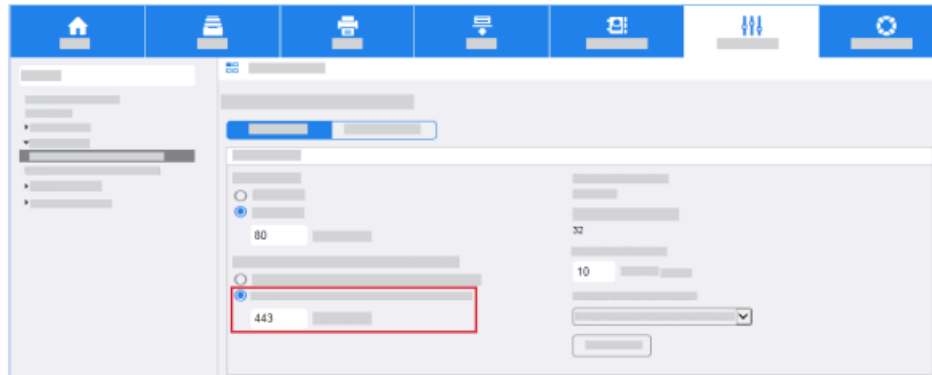

- c. From the Choose Device Certificate menu, select the required certificate.

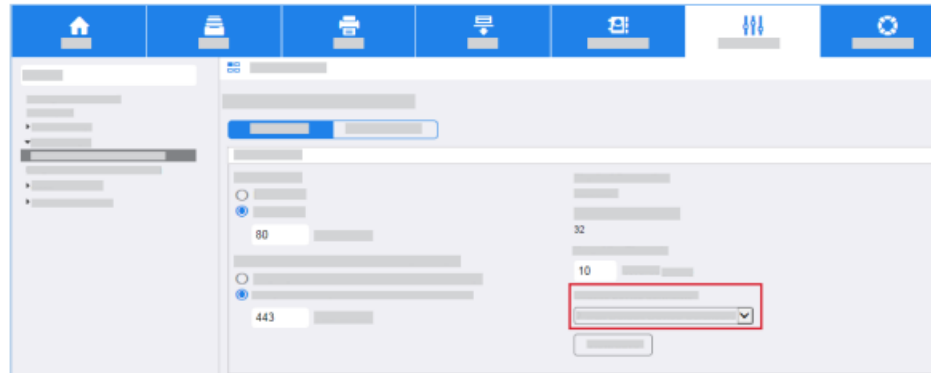

3. If you made changes, click Save. The device restarts automatically. If you have not made changes, click Cancel.

CONFIGURE CERTIFICATE VALIDATION INFORMATION

To configure certificate validation information, perform the following steps. If you do not require certificate validation, proceed to [Configure Smart Card Inactivity Timer](#).

1. Click the Properties tab, then click the Login/Permissions/Accounting link.
2. Click Login Methods.
 - a. From the Configuration Settings list, for Certificate Validation click Edit.

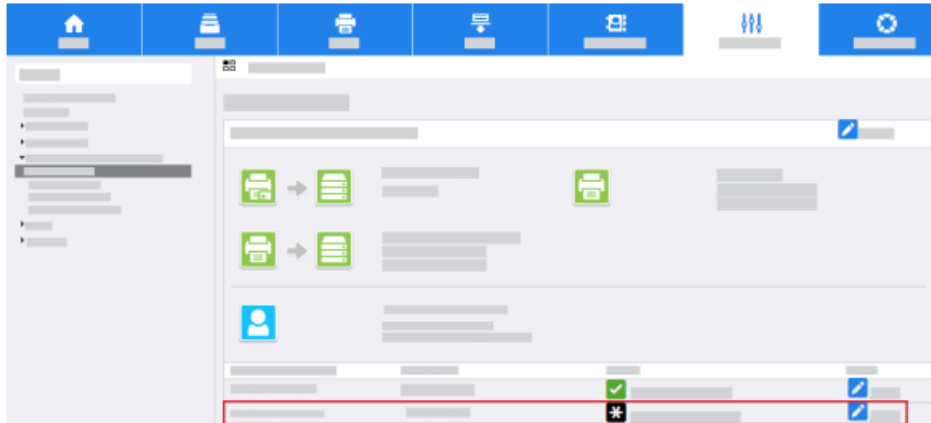

- b. Select the required validation options.

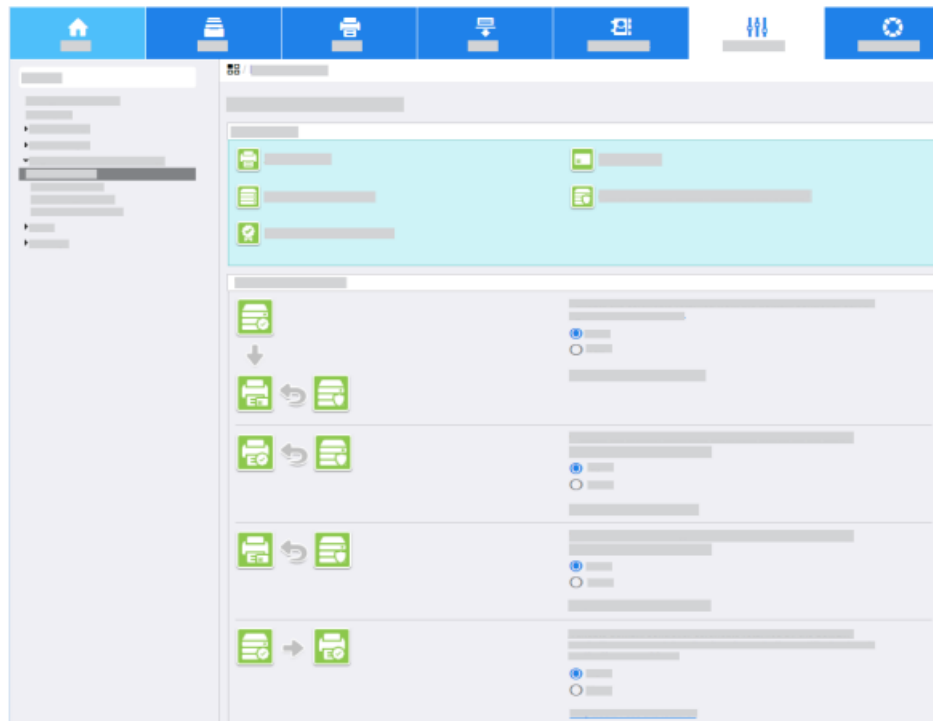

3. If you have selected one or more options, to configure further settings, click Next.
4. If prompted, enter the OCSP server URL for certificate validation.

5. If prompted, to enter the proxy server information, for Proxy Server, click Configure. If the OSCP server is outside the firewall, a proxy server can be required to access the server.

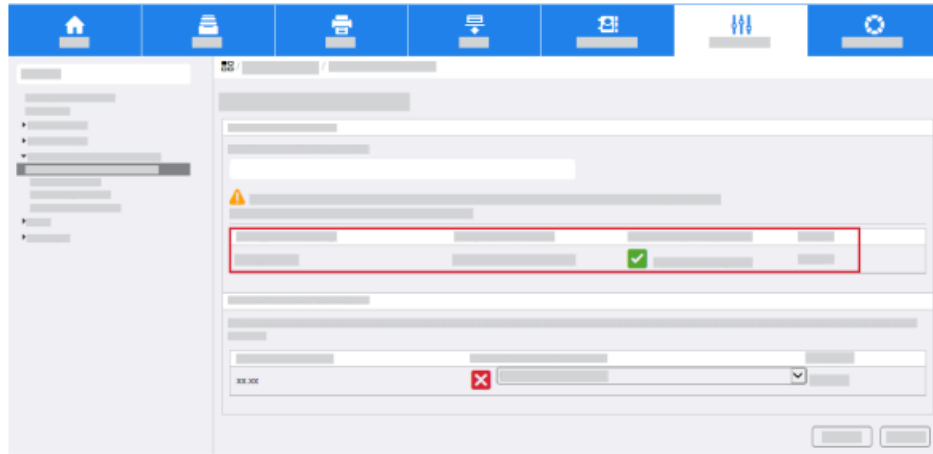

6. To validate each domain controller, select the domain controller certificates required.

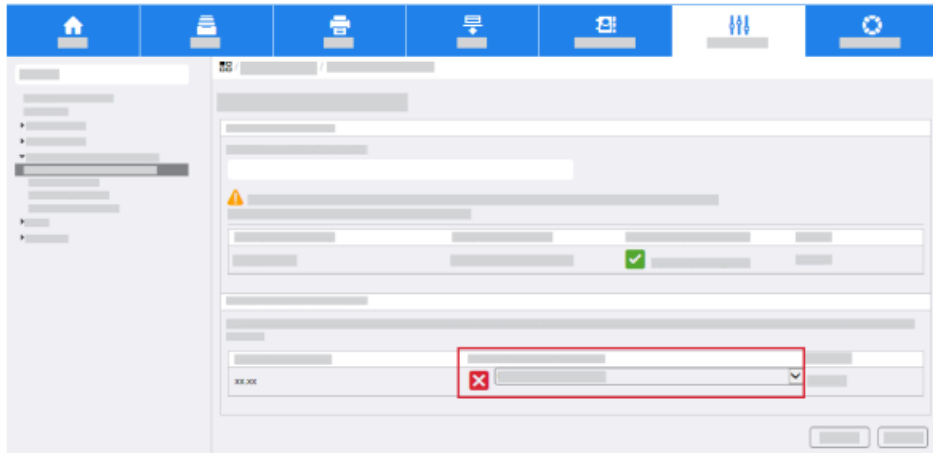

7. Click Save

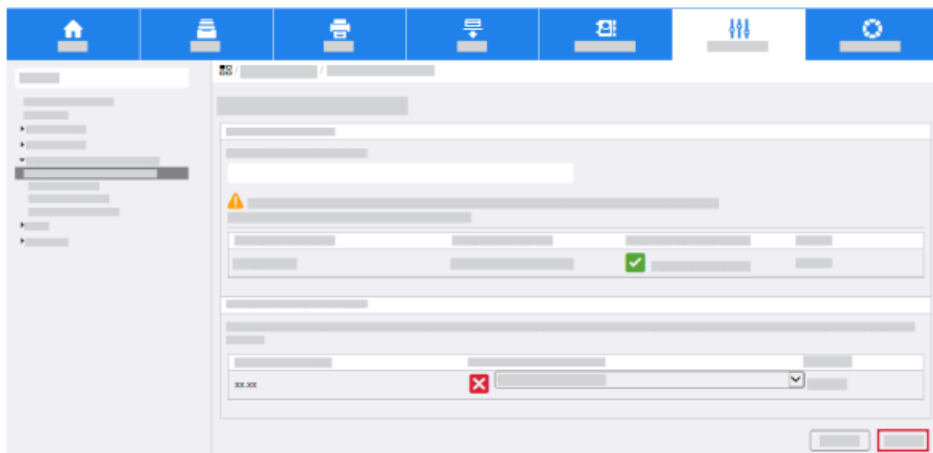

CONFIGURE SMART CARD INACTIVITY TIMER

To configure the smart card inactivity timer, perform the following steps. If you do not require inactivity settings for smart card authentication, proceed to Configure Acquiring Logged-In User Email Address.

1. Click the Properties tab, then click the Login/Permissions/Accounting link.
2. Click Login Methods
 - a. For Smart Card Inactivity Timer, click Edit.

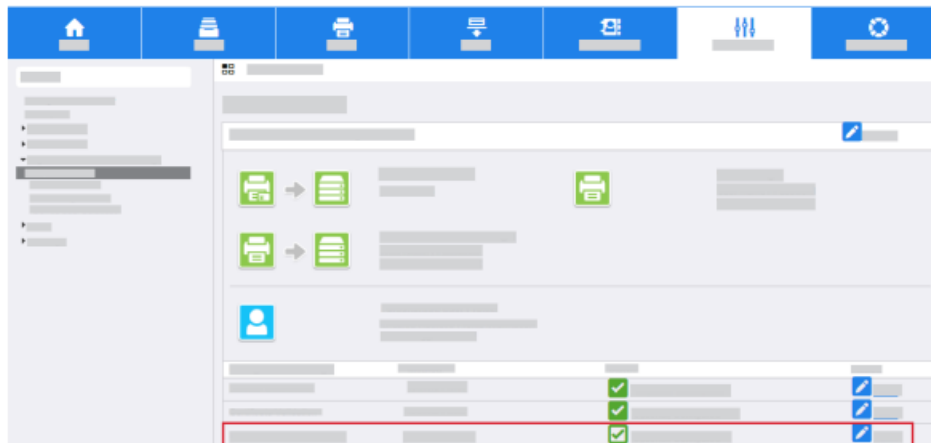

- b. For Timer, enter the required number of minutes.

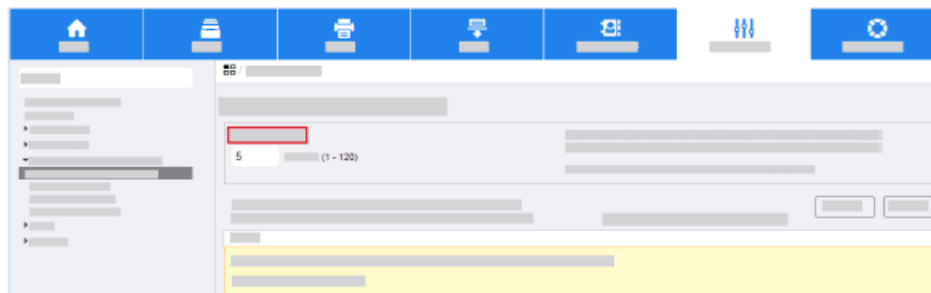

3. Click Save.

CONFIGURE ACQUIRING LOGGED-IN EMAIL ADDRESSES FOR USERS

To configure LDAP and SMTP server information, perform the following steps. If you do not want to configure the settings for Configure Acquiring Logged-In Email Addresses for Users, proceed to Confirm the Installation.

1. Click the Properties tab, then click the Login/Permissions/Accounting link.
2. Click Login Methods.
 - a. For Acquiring Logged-In Email addresses for Users, click Edit.

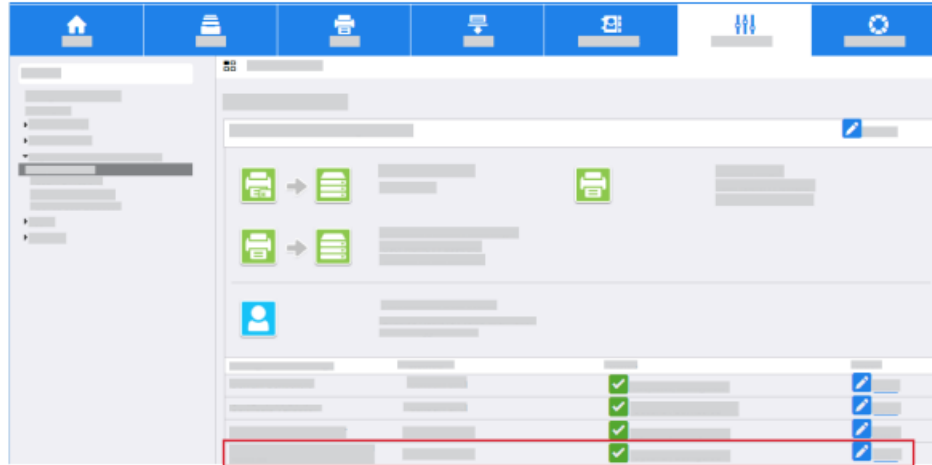

- b. Select the required option for Acquire Logged-In Email Addresses for Users.

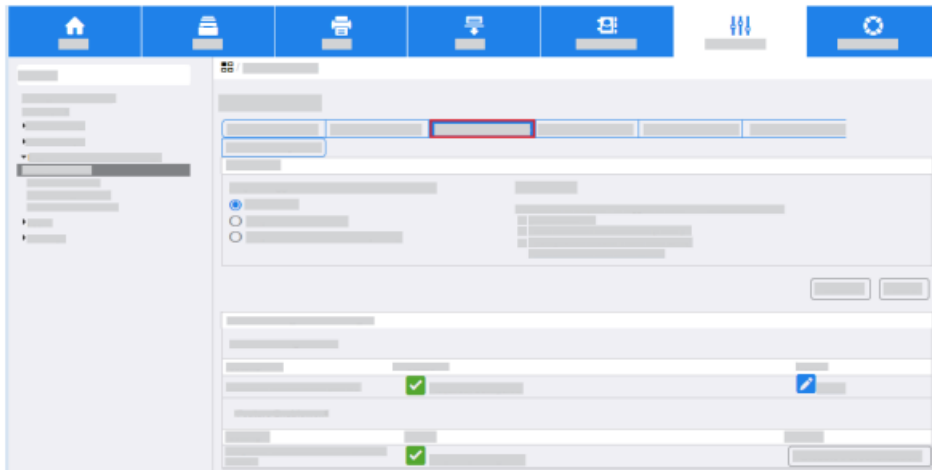

- c. If you select Auto or Only Network Address Book (LDAP), configure LDAP server settings. For Network Address Book (LDAP), click Edit.

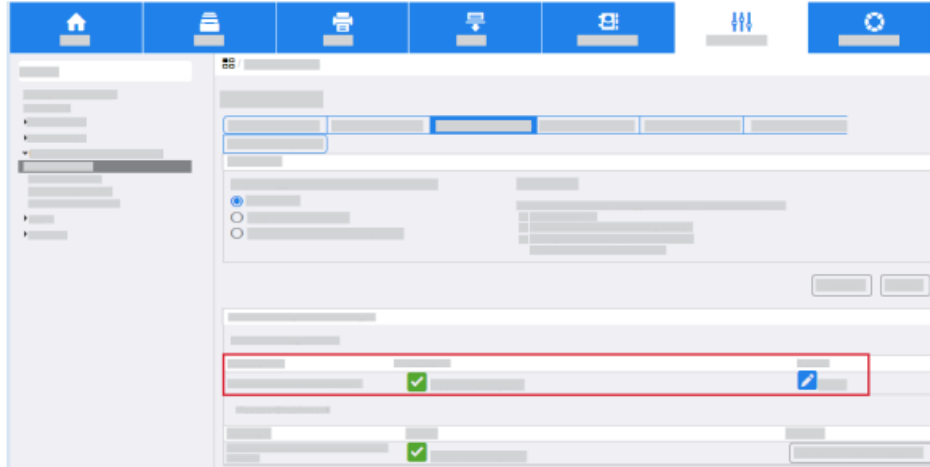

- d. Click Add New.
- e. At the LDAP Server screen, enter a friendly name.

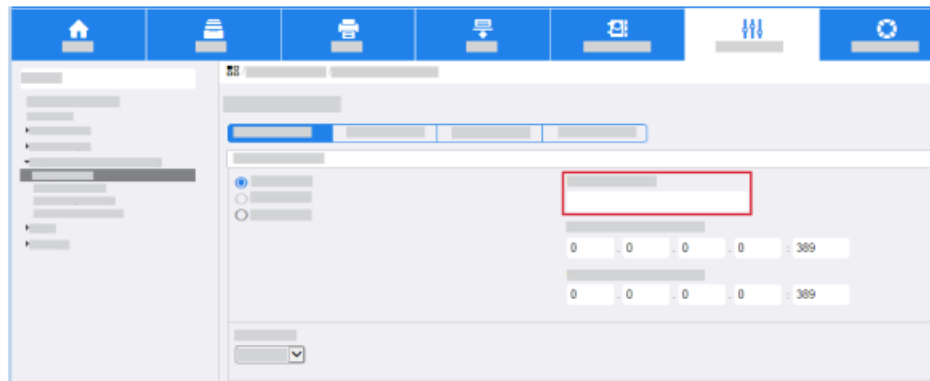

- f. Enter the IP address or host name of the primary and alternate LDAP server.

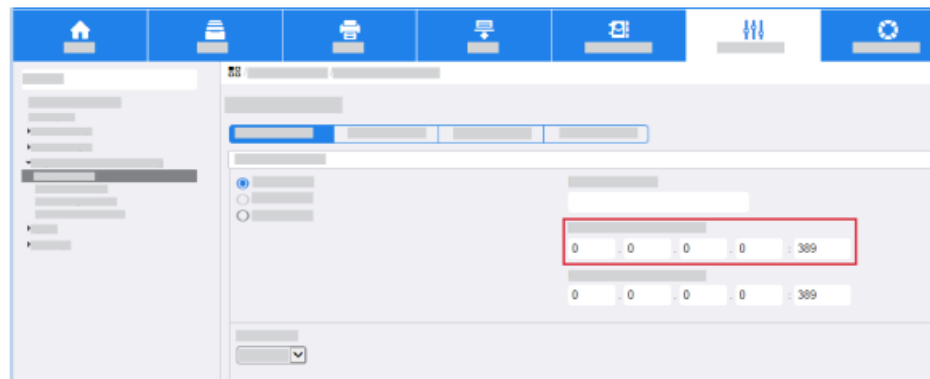

- g. From the list, select the required LDAP server.

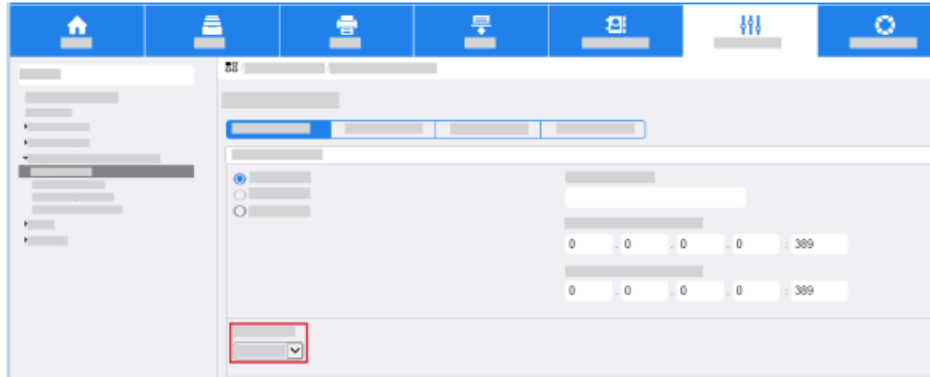

- h. Enter the LDAP search directory root. Typically, this directory root is related to the domain name for the server. For example, if the fully qualified domain name for the server is Hostname.Example.Search.Root the search directory root is dc=Example,dc=Search,dc=Root.
- i. For Login Credentials to Access LDAP Server, enter the required information.
- j. Click Apply.

3. Click Close.

4. Select LDAP Policies.



a. Select Enable SASL Binds to LDAP.

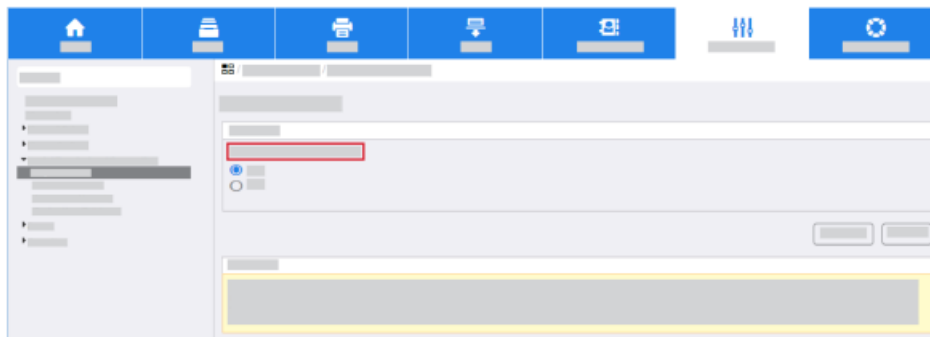

Note: Smart Cards use a ticket-based authentication to LDAP and require SASL for authentication.

b. Click Save.

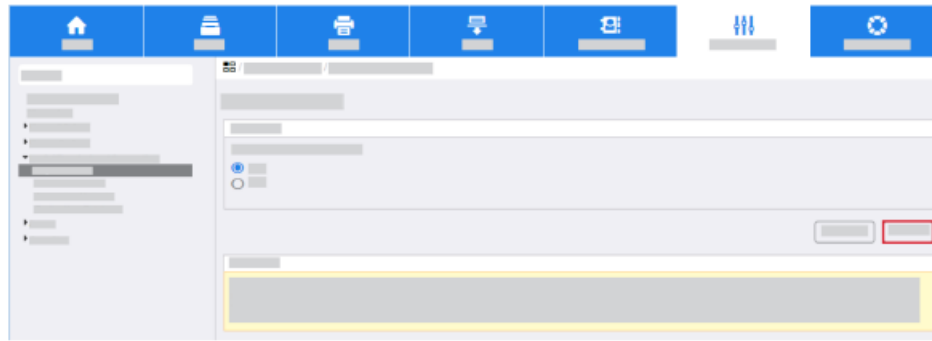

5. Click Close.

CONFIGURE SMTP EMAIL SETTINGS

To configure SMTP email settings, perform the following steps:

1. Click the Properties tab.
2. Click Apps→Email→Setup.
3. In the Email Setup screen, click the Required Settings tab.

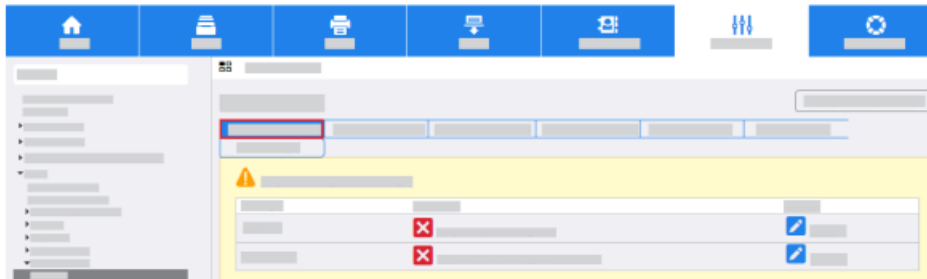

a. For SMTP, click Edit.

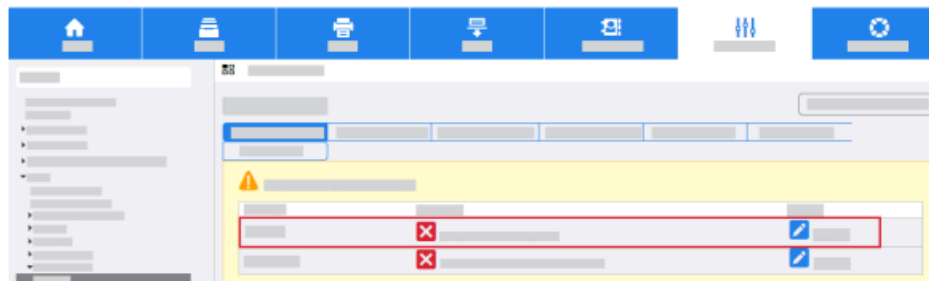

b. To configure the server address, click Use DNS (to identify SMTP Server). Or, click IP Address or Host Name, then enter the SMTP server address.

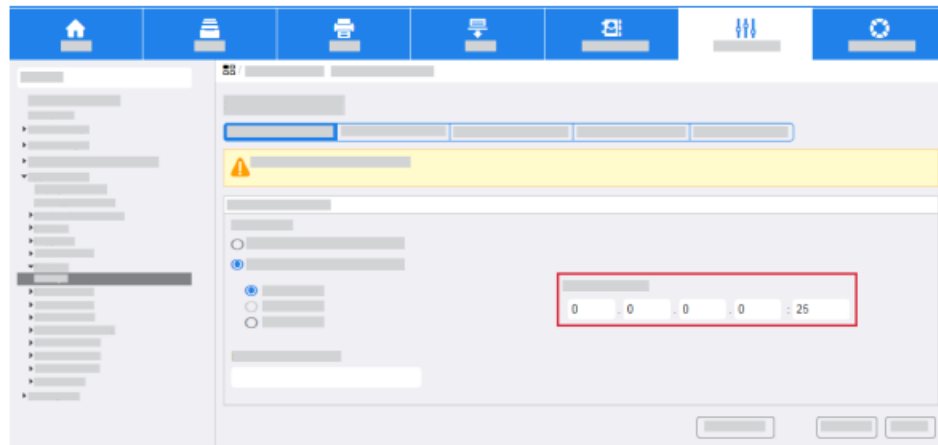
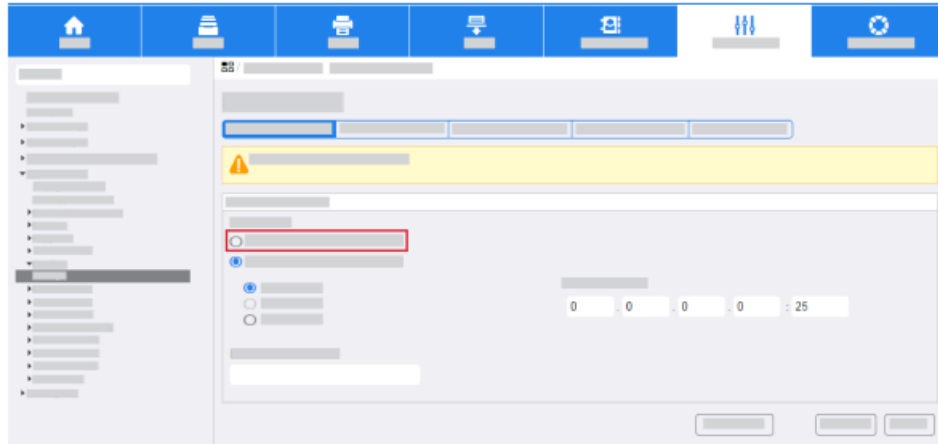

c. For Device E-mail Address, enter the required information.

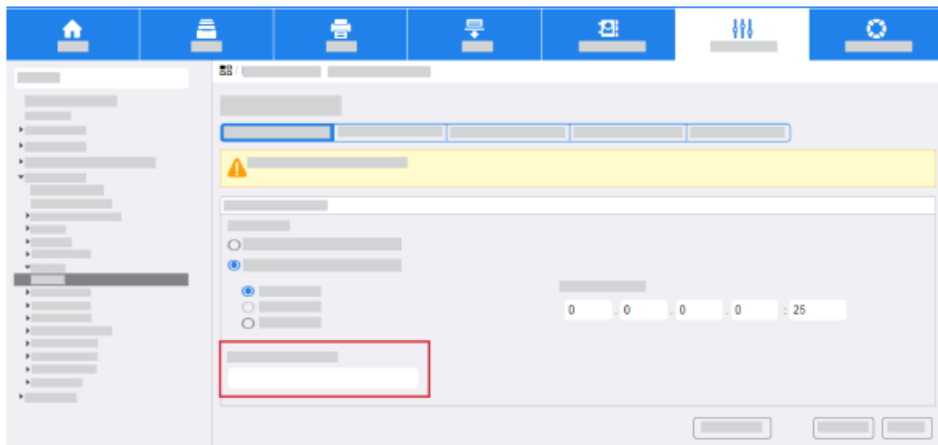

4. Click Save.

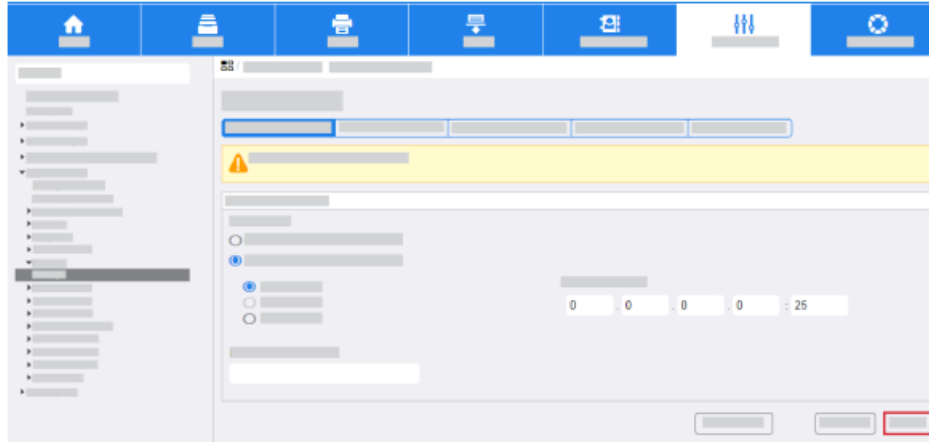

CONFIGURE SMTP AUTHENTICATION

To configure SMTP authentication, perform the following steps.

1. Click the Properties tab.
2. Click Apps→Email→Setup.
3. For SMTP, click Edit.

- a. Click the SMTP Authentication tab.

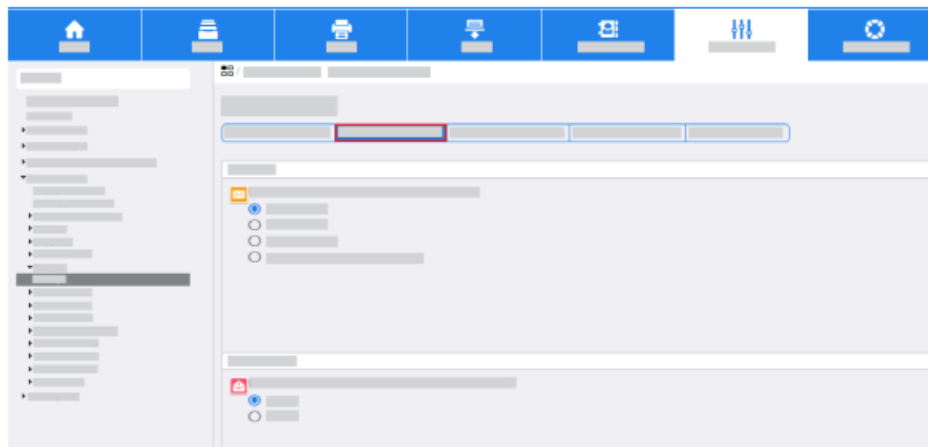

- b. For the required method of authentication, select for SMTP. For Login credentials used for user initiated email jobs, select Logged-in User. Note: The credentials for the logged-in user typically provide authentication for the SMTP server when you enable Smart Card authentication.

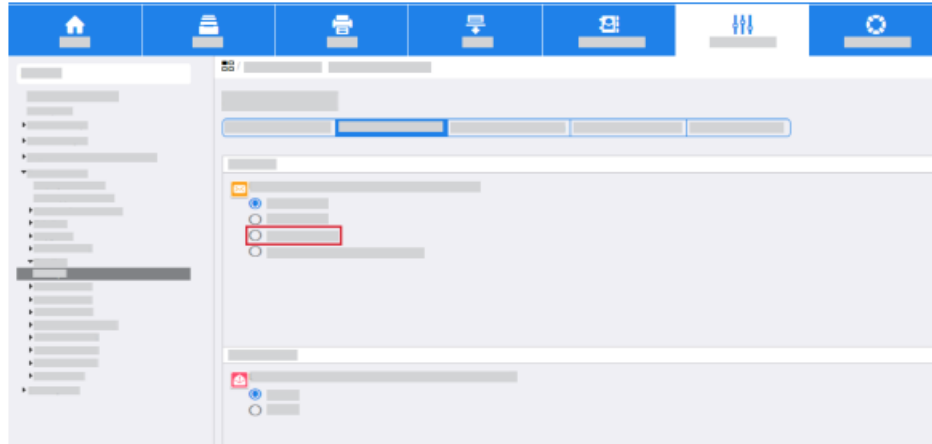

c. Click Always Use Kerberos Tickets.

d. For automated emails, click None.

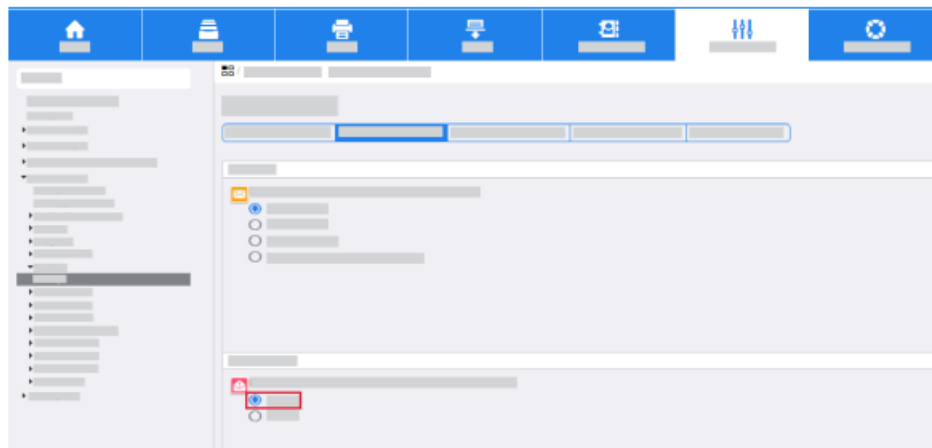

4. Click Save.

CONFIGURE CONNECTION ENCRYPTION

To configure connection encryption, perform the following steps.

1. Click the Properties tab.
2. Click Apps→Email→Setup.
3. For SMTP, click Edit.

- a. Click the Connection Encryption tab.

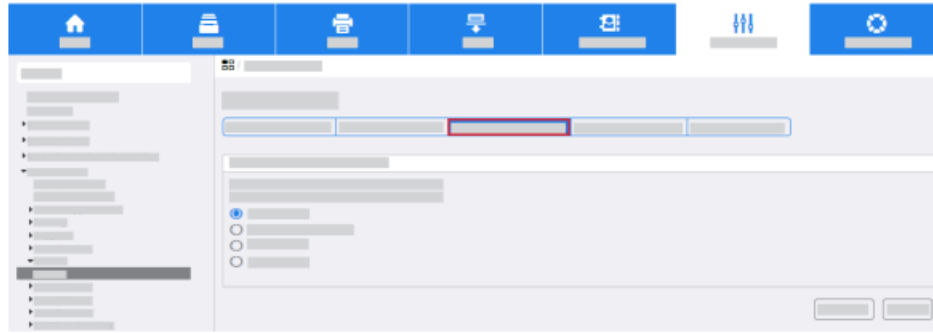

- b. Select the required encryption setting.

4. Click Save.

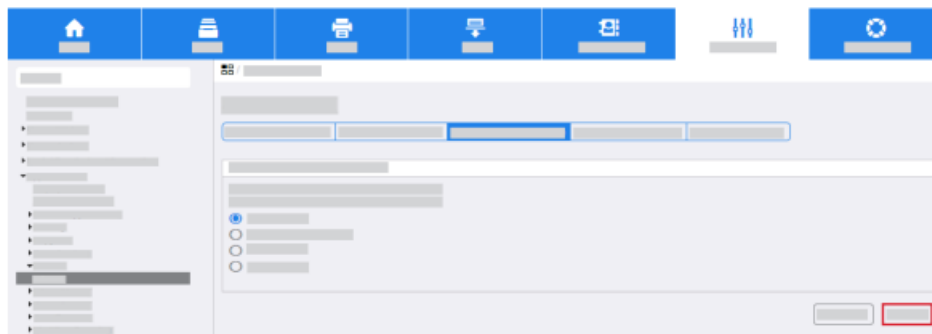

CONFIGURE FILE SIZE MANAGEMENT

To configure file size management settings, perform the following steps:

1. Click the Properties tab.
2. Click Apps→Email→Setup.
3. For SMTP, click Edit.
 - a. Click the File Size Management tab.

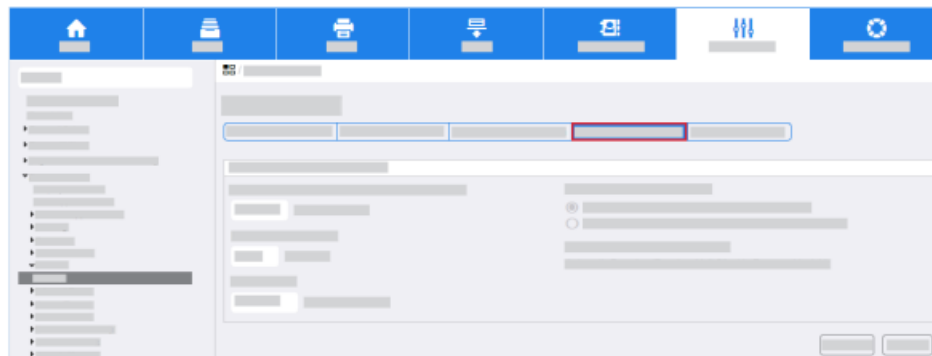

Note: This screen defines how to manage large email payloads.

- b. Select the required settings.

4. Click Save.

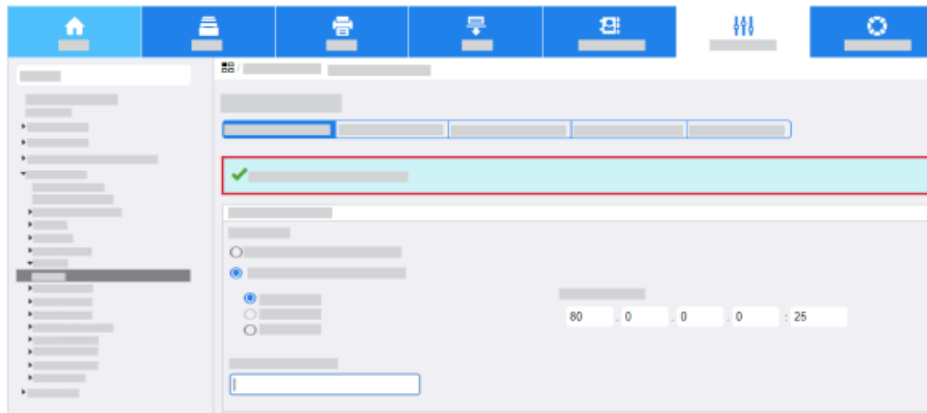
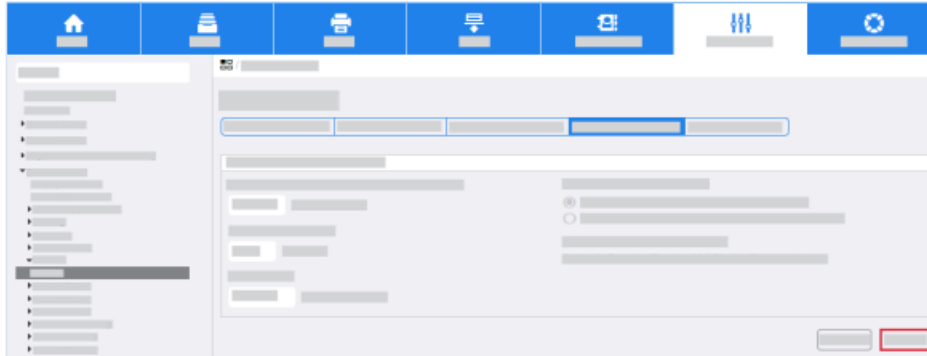

TEST CONFIGURATION

To enter test configuration settings, perform the following steps:

1. Click the Properties tab.
2. Click Apps→Email→Setup.
3. For SMTP, click Edit.
 - a. Click the Test Configuration tab.

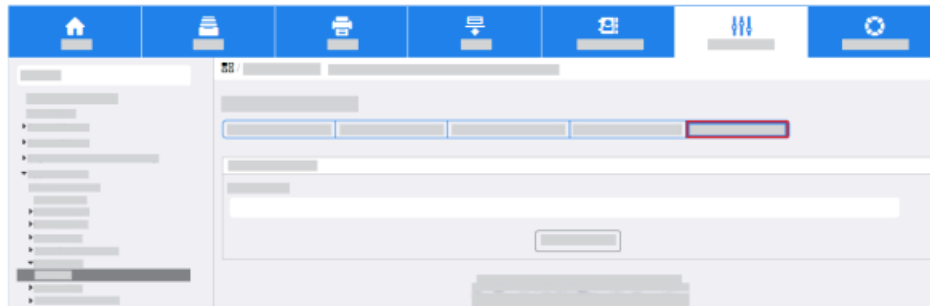

Note: This screen allows you to send a test email to confirm that all email settings are correct.

- b. In the To Address field, enter a valid email address.

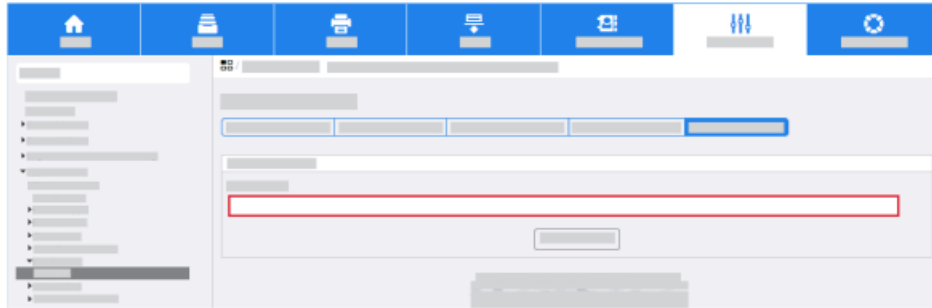

- c. Click Send Email. Note: If the SMTP settings are correct, a success message appears and an email is received at the address.

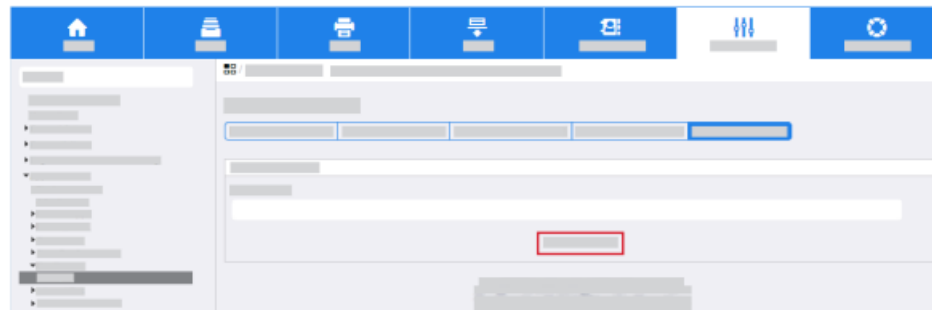

- 4. Select the Required Information tab. If the required settings are configured correctly, the message Required Settings Configured appears.

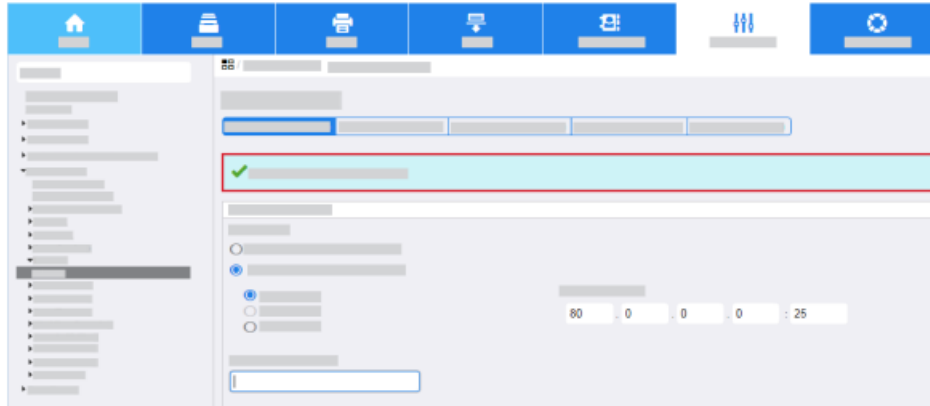

- 5. Click Save.

CONFIGURE GENERAL EMAIL SETTINGS

To configure general email settings, perform the following steps:

1. Click the Properties tab.
2. Click Apps→Email→Setup.
3. Click the General tab.

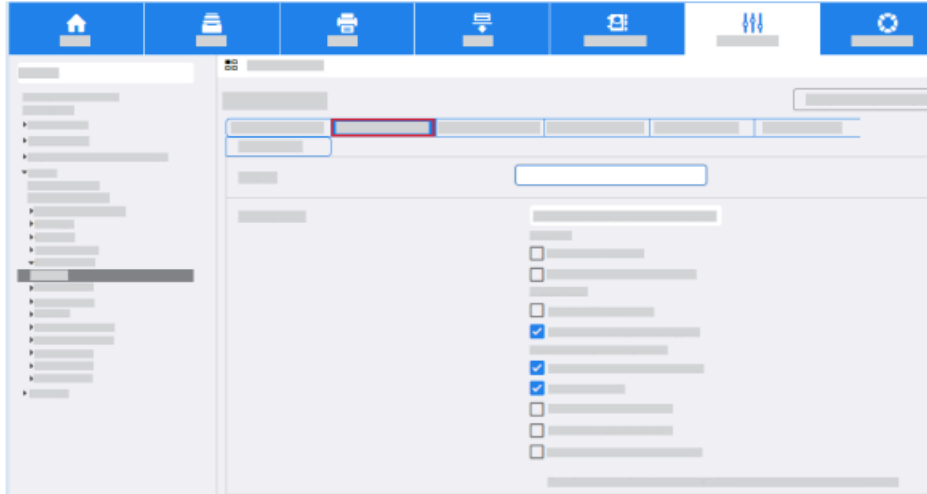

- a. Enter the required information to appear in the Subject line of an email that is sent from the multifunction printer.

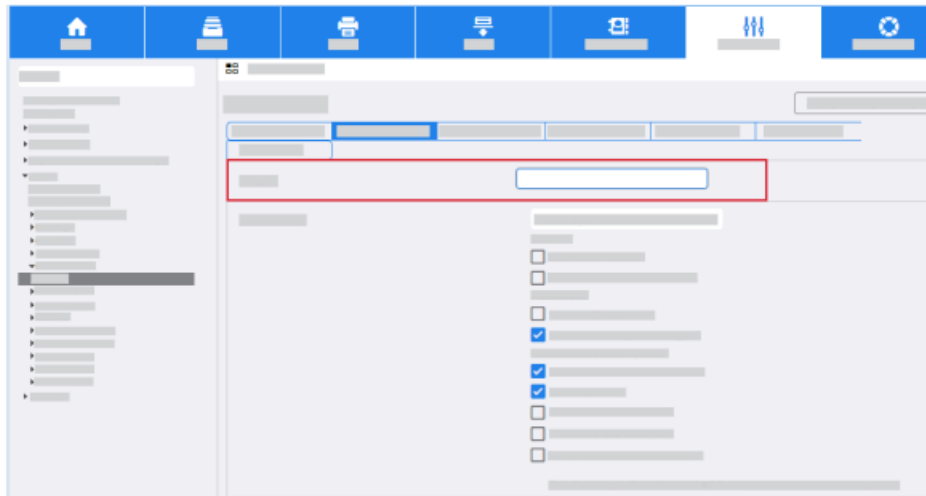

- b. For Message Body, select the required information that you want to appear in the body of an email.

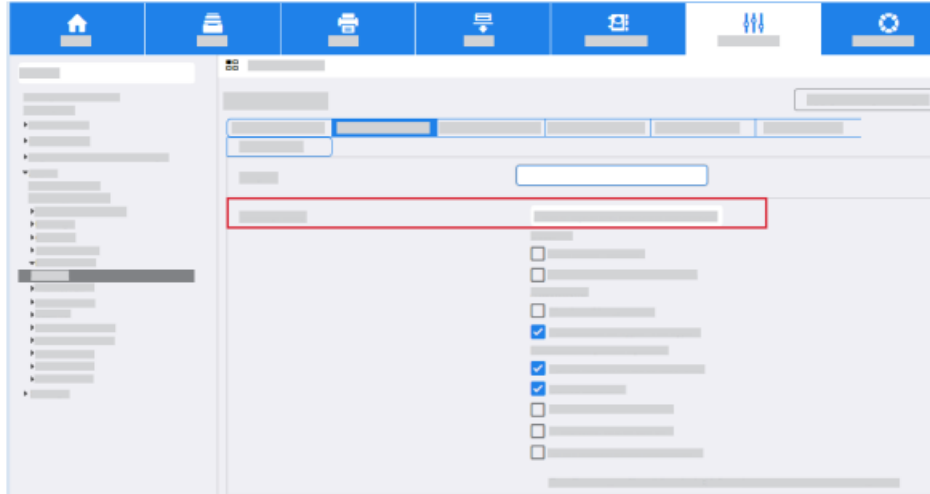

- c. For the Signature field, enter the information that you want to include in an email signature.
 - d. To print a confirmation sheet, from the menu, select the required option.
 - e. If you want the multifunction printer to add your email address automatically to the To field when you are logged in, for Auto Add Me, click Enabled.
4. Click Apply.

CONFIGURE ADDRESS BOOKS

To configure address books, perform the following steps:

1. Click the Properties tab.
2. Click Apps→Email→Setup.
3. Click the Address Books tab.

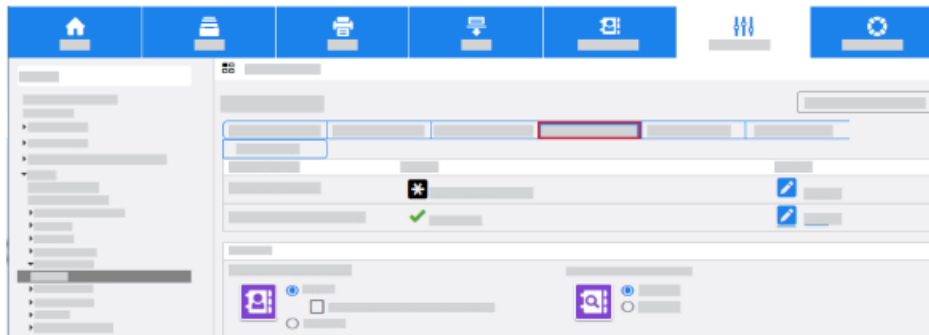

4. LDAP was configured in a previous step. To configure the device address book, for Device Address Book, click Edit.

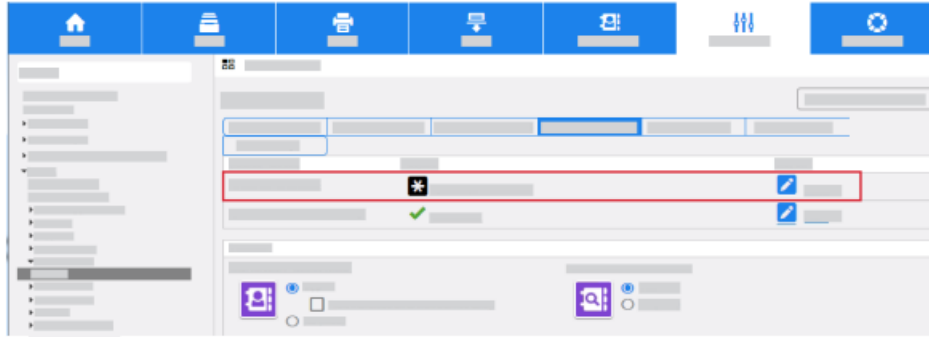

5. Configure the device address book. For more information, refer to the System Administrator Guide for your Xerox multifunction printer.

CONFIGURE EMAIL DEFAULTS

To configure default email settings, perform the following steps:

1. Click the Properties tab.
2. Click Apps→Email→Setup.
3. Click the Defaults tab.

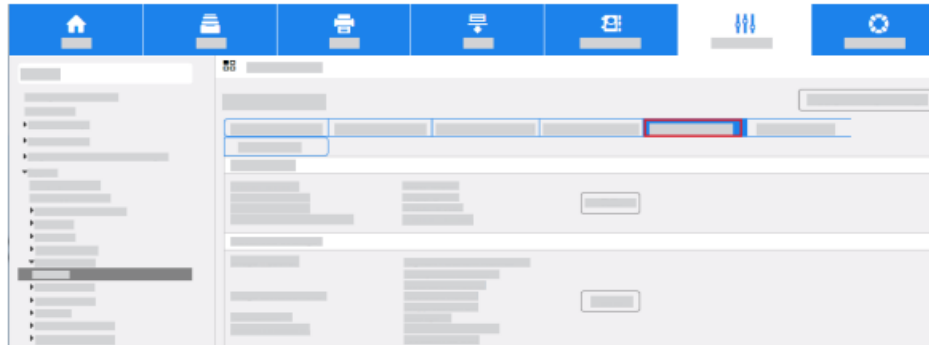

4. For default email settings, click Edit, then select the required options. To save selections, click Save.
5. Click Apply

CONFIGURE EMAIL COMPRESSION

To configure email compression settings, perform the following steps:

1. Click the Properties tab.
2. Click Apps→Email→Setup.
3. Select the Compression tab.

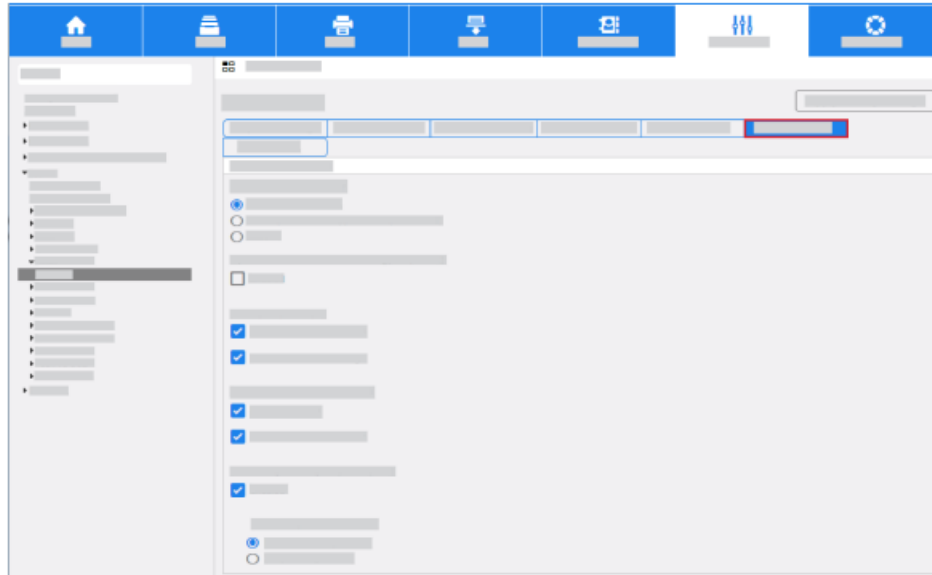

4. For Compression Settings, select the required settings.
5. Click Save

CONFIGURE EMAIL SECURITY

To configure email security settings, perform the following steps:

1. Click the Properties tab.
2. Click Apps→Email→Setup.
3. Click the Security tab.

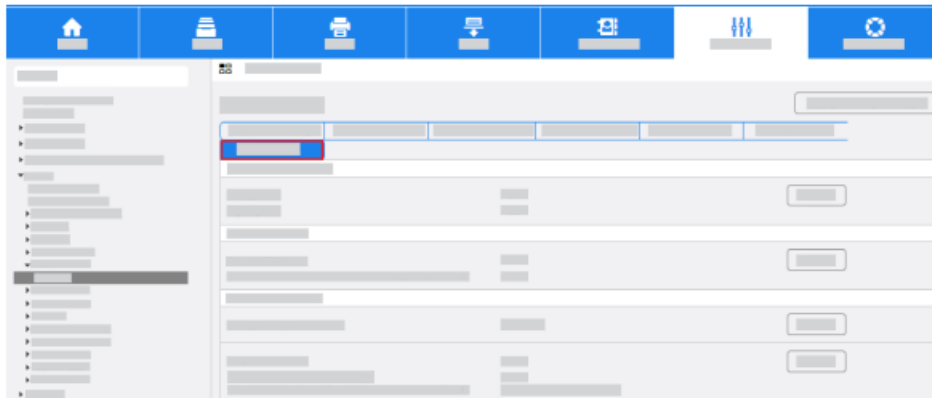

a. For Encryption/Signing, click Edit.

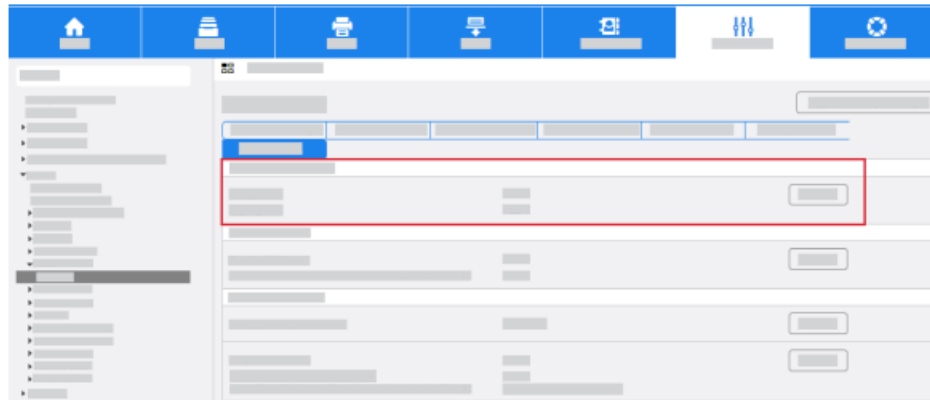

b. Select the required Enablement setting:

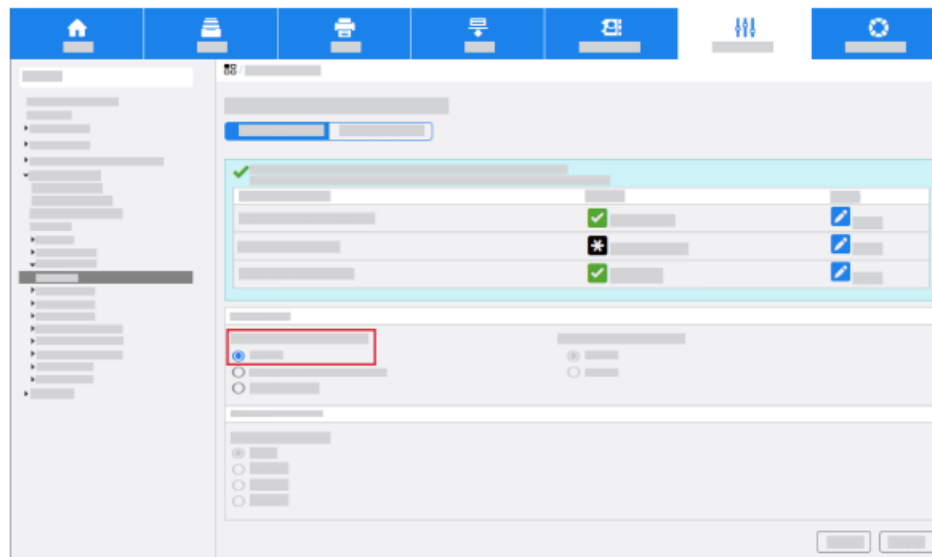

- Off: You cannot sign email.
- Always On: An email signature is required.

- Editable by user: The local user settings determine if an email signature is required.

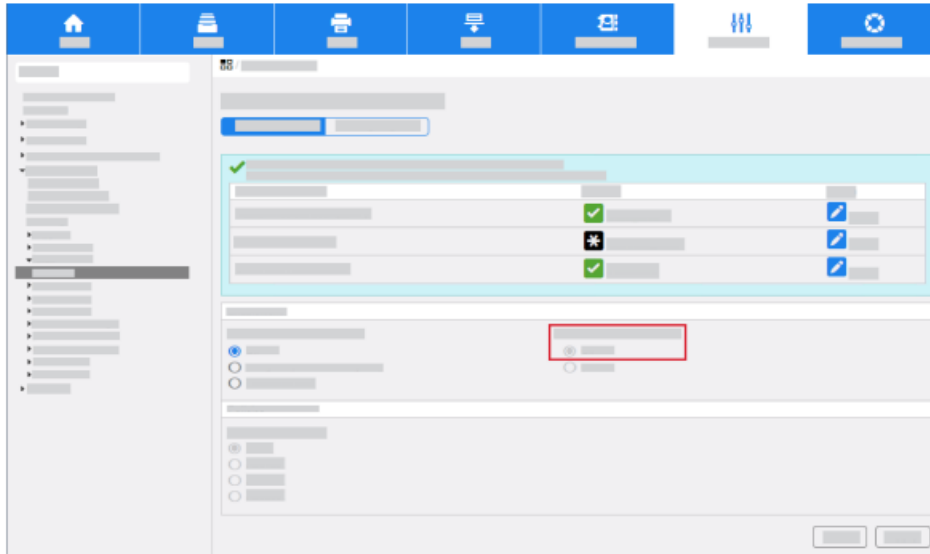

- If you selected Editable by User, and if the ability to sign is required by default, for the Email App Encryption Default setting, click On.

- For Encryption Algorithm, select the required setting.

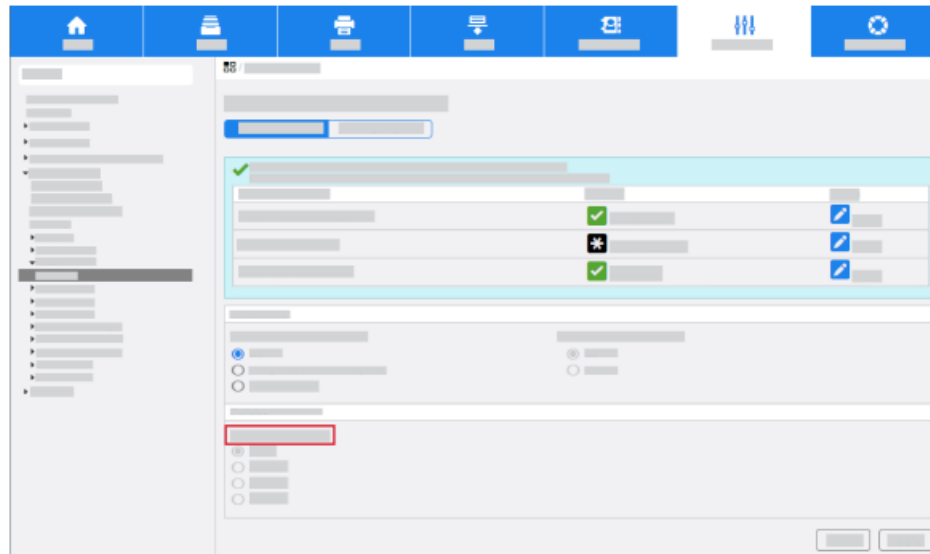

e. Click Apply.

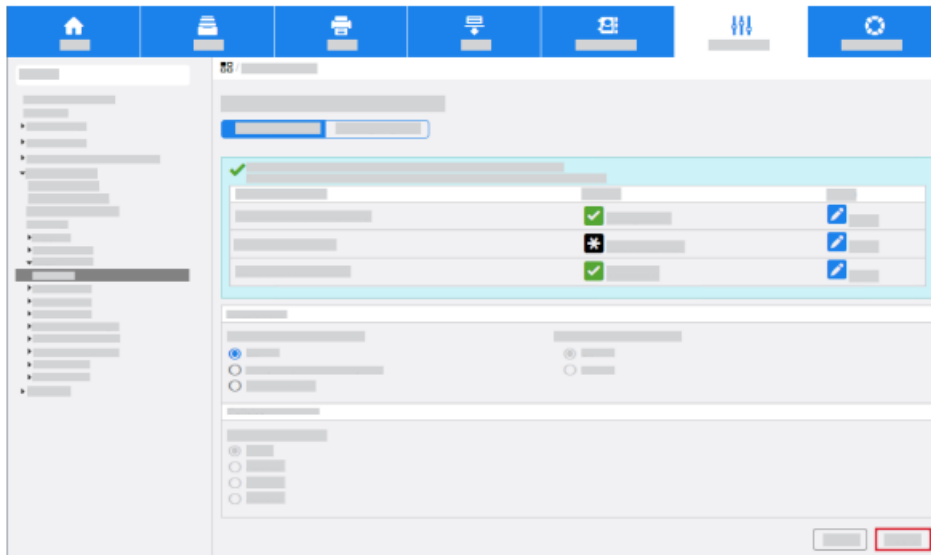

4. If you want to configure email domain restrictions, in the Network Policies area, click Edit.

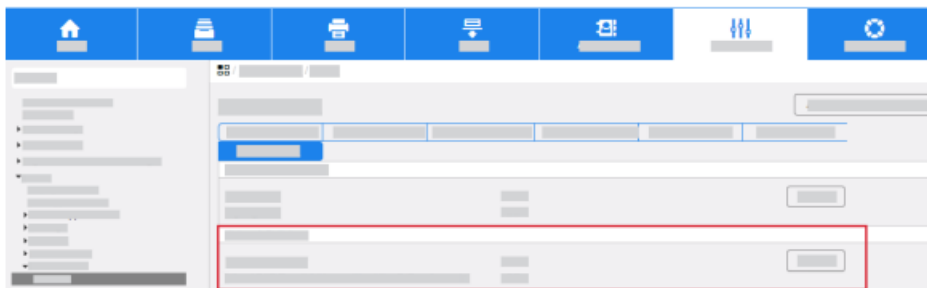

a. Select the required restrictions.

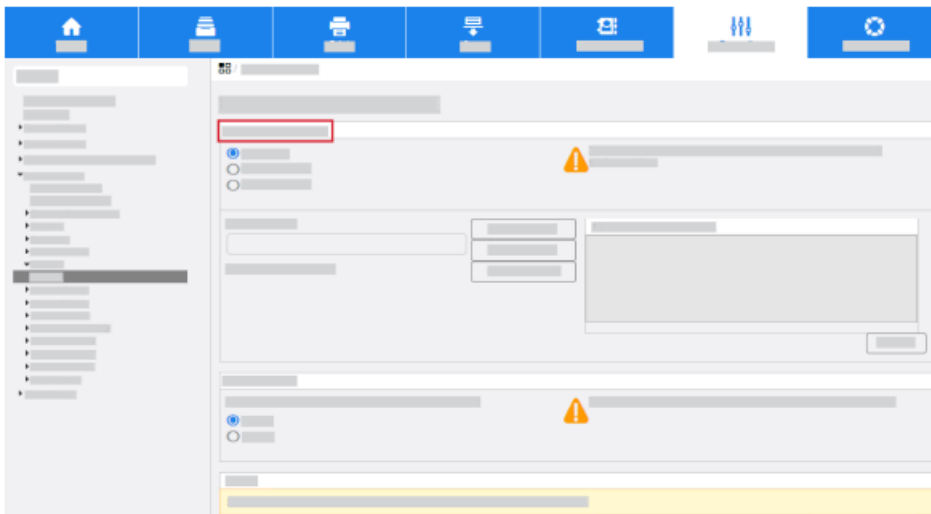

- Domain Filtering: This option enables you to configure a list of domains to allow or block emails.

- Email Filtering: This option allows you to send internal email without a corporate name. This option requires configuration of your email server.

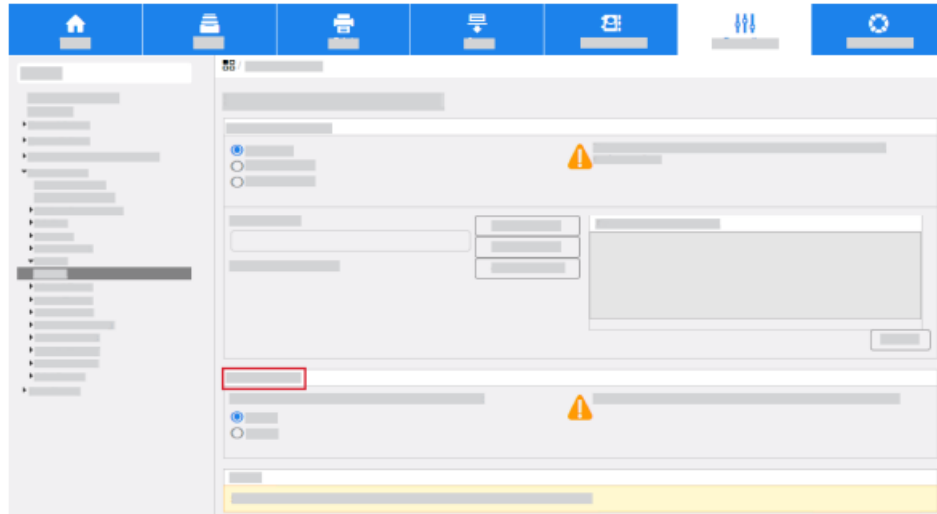

b. Click Save.

5. If you want to configure restrictions on email recipients, in the User Policies area, click Edit.

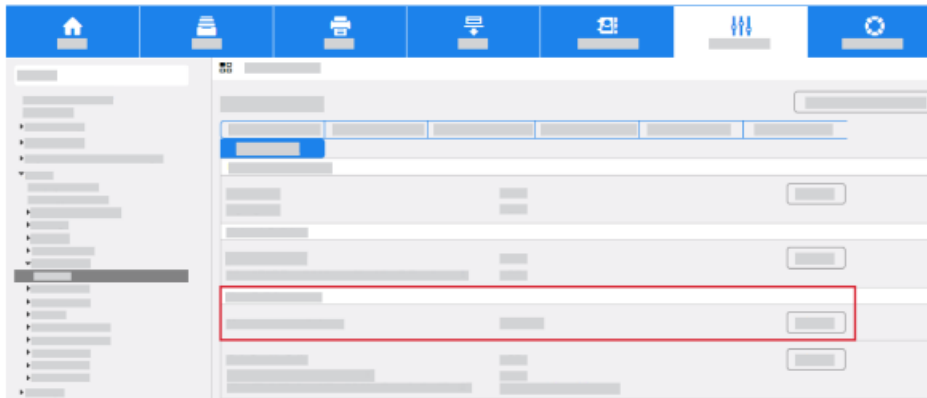

- a. Select the required settings for User Permissions.
- b. Click Save.
- c. If necessary, in the Only Send to Self area, click Edit.

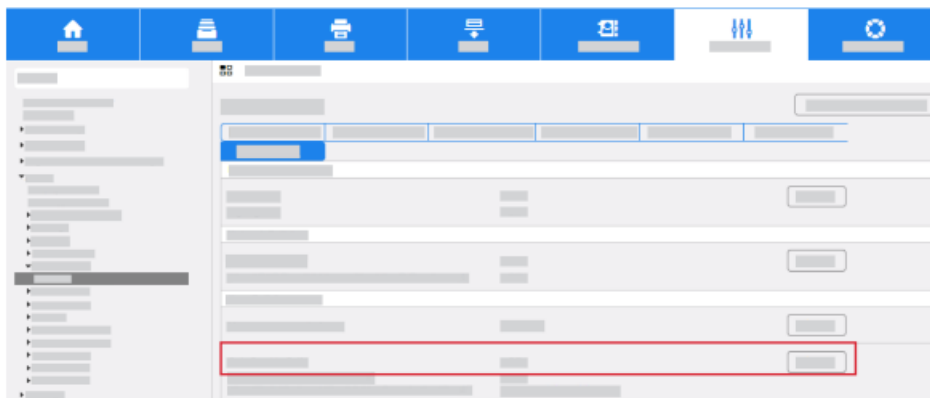

- d. Select the required Security settings.
- e. Click Save.

The configuration of the smart card settings is complete

6. Printing Features

To hold jobs at the multifunction printer until you authenticate at the control panel, configure the Hold All Jobs and Secure Print features.

CONFIGURE HOLD ALL JOBS

The Hold All Jobs feature allows you to configure the multifunction printer to require users to release print jobs manually at the control panel. If you want to configure Hold All Jobs, perform the following steps:

1. Access the Embedded Web Server, then click the Properties tab. For more information, refer to [Accessing Administration and Configuration Settings](#).
2. Click Apps→Printing→Hold All Jobs.
 - a. Select the required Enablement option:

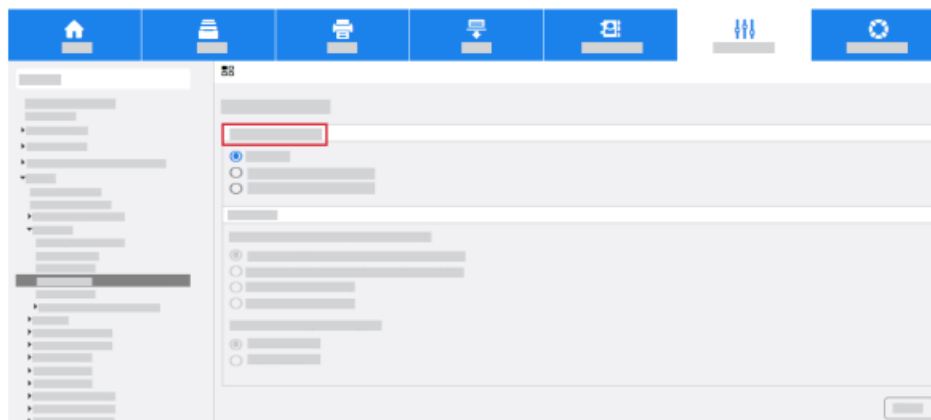

- Hold Jobs in a Private Queue: This option holds jobs in a locked folder. Users are required to log in at the control panel to view, print, and delete jobs.
- Hold Jobs in a Public Queue: This option holds sent jobs in an unlocked folder. Users are not required to log in at the control panel.

- b. Select the required option for Unidentified Job Policies (Unknown User ID). For more information, refer to the System Administrator Guide for your Xerox multifunction printer.

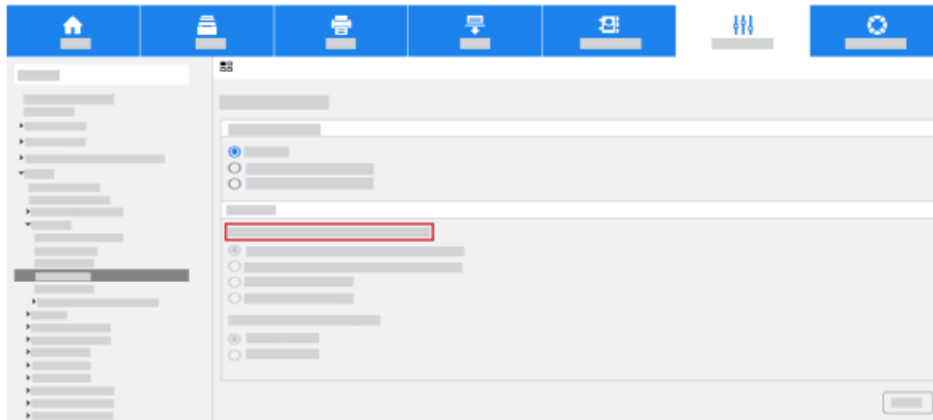

CONFIGURE SECURE PRINT DRIVER DEFAULTS

The Secure Print feature allows you to send a job to the multifunction printer with a unique passcode. Jobs are stored at the printer until you enter the same passcode to release the jobs. For more information about how to use Secure Print, refer to the User Guide for your Xerox multifunction printer. You can configure the settings to require a User ID instead of a passcode to release jobs at the control panel.

To configure the Secure Print driver defaults, perform the following steps:

1. Access the Embedded Web Server, then click the Properties tab. For more information, refer to Accessing Administration and Configuration Settings.
2. Click Apps→Printing→Secure Print.
 - a. Click the Defaults tab.

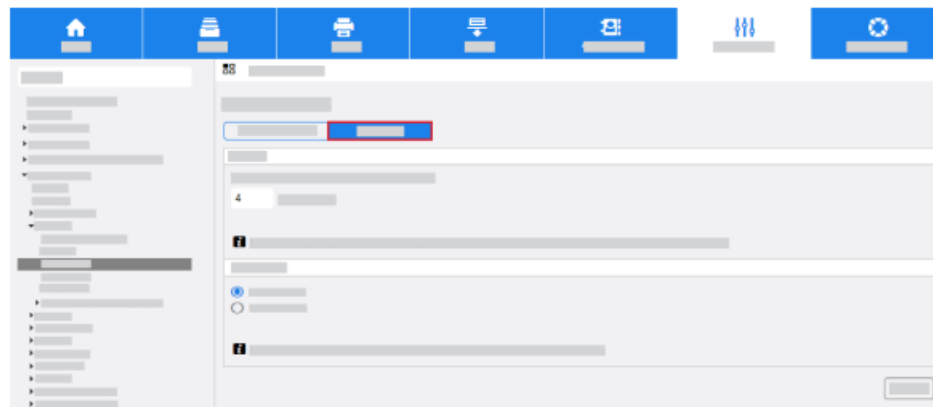

b. Select the required release method.

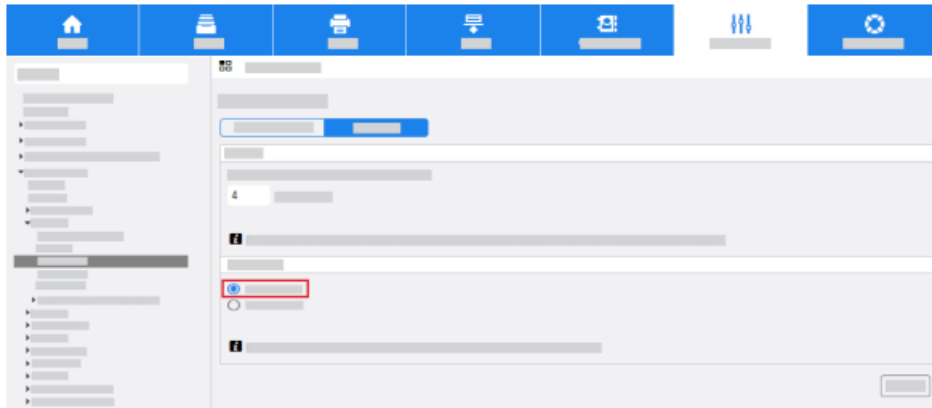

- Passcode: This option requires that you type a passcode to release your Secure Print jobs at the control panel. If required, enter a number from 4–10 to specify the length of the Secure Print passcode.
- User ID: This option requires you to log in at the control panel to release your Secure Print jobs.

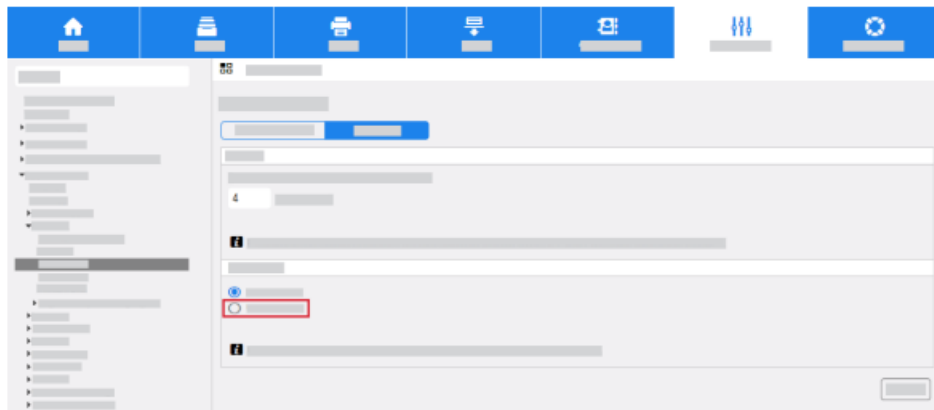

c. Click Save.

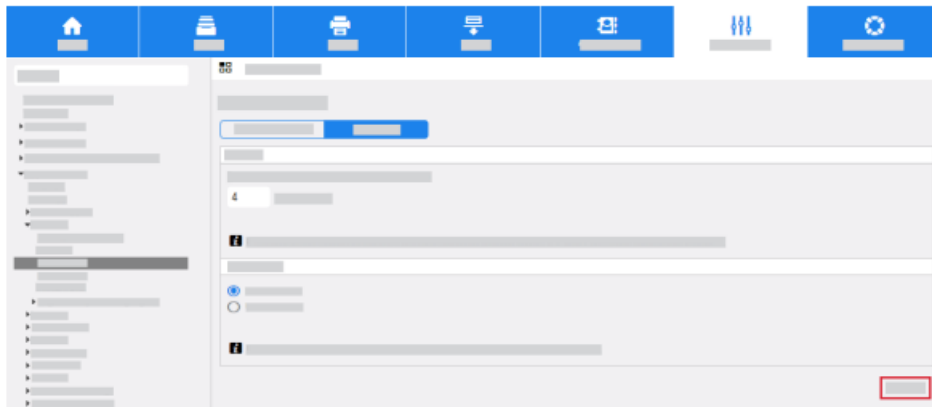

For more information on how to configure Secure Print settings, refer to the System Administrator Guide for your Xerox multifunction printer.

CONFIGURING THE PRINT DRIVER

You can configure your print driver to pull the user name alias from the smart card certificate, or from the Windows operating system. To configure the print driver to pull the user name from the smart card certificate, install the Xerox print driver for your Xerox printer. For more information, refer to the System Administrator Guide for your Xerox multifunction printer.

1. Install your Xerox® Print Driver.



2. Access the properties for your print driver.
3. Click the Administration tab.

4. From the Access and Verification menu, select Enabled.



5. Click OK.



Note: If you configure Hold All Jobs or Secure Print Driver defaults at the multifunction printer, the settings can override the settings in your print driver. For more information, refer to [Configure Hold All Jobs](#) and [Configure Secure Print Driver Defaults](#).

7. Confirm the Installation

When you install and configure the card reader and the software, the Card Reader Detected screen appears on the Xerox® multifunction printer control panel touch screen. The smart card is now ready for use.

Note: If the card reader is not detected, refer to Troubleshooting Tips.

USING THE SMART CARD

When the Smart Card solution is installed and enabled, insert a valid card, then enter your Personal Identification Number (PIN) on the touch screen. When you finish, to end the session, remove your card from the card reader. If you forget to remove your card, the printer ends the session automatically after a specified period of inactivity. To use the Smart Card, perform the following steps: The Authentication Required window can appear on the touch screen, if that is how your device is configured.

1. Insert your card into the card reader.
2. Use the touch screen and numeric keypad to enter your PIN, then touch Enter.

If the card and PIN are authenticated, access is granted.

Note: If the access attempt fails, refer to Troubleshooting Tips.

3. Complete the job.
4. To end the session, remove your card from the card reader.

The current session is terminated and the Authentication Required window appears.

8. Troubleshooting

For optimal performance from your card reader, follow these guidelines:

- Ensure that the card reader is compatible with network-connected products only.
- Ensure that the card reader is plugged into the network controller. Refer to [Connect the USB Smart Card Reader to the Printer](#).
- Do not position the card reader in direct sunlight or near a heat source, such as a radiator. Ensure that the card reader does not get contaminated with dust and debris.
- To clean the outer surfaces of the card reader, use a lint-free cloth moistened with water and a mild detergent. Wipe the outer surfaces of the card reader with the lint-free cloth.

FAULT CLEARANCE

When a fault occurs, a message appears on the printer control panel touch screen. The message provides information to clear the fault. If you cannot resolve the fault using the onscreen instructions, refer to Troubleshooting Tips.

If the problem persists, identify if the problem is related to the card reader device or the Xerox® printer:

- For problems with the card reader device, for further assistance, contact the manufacturer.
- For problems relating to the Xerox® printer:
 - Before you contact Xerox Technical Support, ensure that you have the printer serial number and the fault code.
 - Contact Xerox Technical Support. Contact Xerox at 1-800-ASK-XEROX or 1-800-275-9376.

LOCATING THE SERIAL NUMBER

At the Xerox multifunction printer control panel, touch Device, then touch About. The printer serial number appears on the About screen.

Note: You can find the serial number inside the front cover of the Xerox multifunction printer.

TROUBLESHOOTING TIPS

The table provides a list of problems, the possible cause, and a recommended solution.

If you experience a problem during the installation process, refer to the [During Installation](#) problem-solving table.

If you installed the Smart Card solution successfully, but you now experience problems, refer to the [After Installation](#) problem-solving table.

DURING INSTALLATION

Problem	Possible Cause	Solution
The card reader is installed but no message appears on the user interface	The card reader is faulty.	<ul style="list-style-type: none">• Try a different card reader. Contact your system administrator.
	The card reader connection is faulty	<ul style="list-style-type: none">• Check that the cable is plugged in correctly. For more information, refer to Connect the USB Smart Card Reader to the Printer.• Unplug the card reader cable, then plug it back in.• Plug the card reader into a different USB port.
	The card reader is not compatible	To verify that the card reader is on the list of compatible devices, refer to Supported Card Readers
	Smart Card access is not enabled on the Xerox multifunction printer.	Use the Embedded Web server to enable Smart Card through the Properties setup screens. For more information, refer to Software Configuration

AFTER INSTALLATION

Problem	Possible Cause	Solution
The login was successful; however you do not have the appropriate access to the operation that you requested.	LDAP is not configured properly, or the local user permission roles are not configured properly.	Verify the authorization method
The passcode entered was incorrect.	<p>Incorrect PIN was entered.</p> <p>Caution: Consecutive incorrect entries can lead to your card being locked.</p>	Carefully re-enter the PIN.

Authentication failed. There is a problem with your card that is preventing successful login.	Certificates cannot be read from the card.	To reload the certificates or get a new card, contact the Registration Authority.
Authentication failed because the device was unable to access the remote server, domain controller, or the authentication sequence failed.	The domain controller IP address or host name is incorrect.	Verify that the server address is entered correctly.
	Incorrect domain.	Verify that the domain is configured properly.
	Network error.	Verify that the network cable is connected firmly.
The number of attempts exceeded the allowable limit.	Card was locked due to failed login attempts.	To reset the PIN or to get a new card, contact the Registration Authority.
Server Certificate Failed. Authentication failed because the remote server or domain controller certificate were not found, are invalid, are expired, or access was revoked.	This problem usually occurs because the device does not trust the certificates on the smart card.	<ul style="list-style-type: none"> • Ensure that all the chain of trust certificates are imported on the multifunction printer. • Verify which root certificate authority and intermediate certificate authority issued the smart card certificates.
The card reader was not detected.	The card reader was disconnected.	<ul style="list-style-type: none"> • Verify that the card reader is connected properly. • If you suspect that the reader has failed, uninstall the card reader, then install a known working card reader.
Invalid time stamp. Authentication failed due to a time or date difference between the device and the remote server, or domain controller.	Invalid time stamp. Authentication failed due to a time or date difference between the device and the remote server, or domain controller.	Verify that Network Time Protocol is set up correctly. Refer to Enable NTP Service .
	GMT offset is not set correctly	<ul style="list-style-type: none"> • If you are not using DHCP, verify that the date, time, GMT offset, and time zone are correct. For more information, refer to the System Administrator Guide for your Xerox printer. • Verify that GMT offset is correct for Daylight Saving Time <p>Note: Unforeseen errors are mapped to this error message.</p>
The devices on your network cannot see	The IP address is incorrect or was reset	<ul style="list-style-type: none"> • Verify that the IP address that is printed on the

the Embedded Web Server pages		configuration report matches the DHCP settings for your site. • To print a configuration report at the Xerox printer, touch Device, then touch Information Pages. Select the configuration report from the list, then touch Print.
-------------------------------	--	---

9. Additional Information and Resources

Security @ Xerox®

Xerox maintains an evergreen public web page that contains the latest security information pertaining to its products. Please see <https://www.xerox.com/security>

Responses to Known Vulnerabilities

Xerox has created a document which details the Xerox Vulnerability Management and Disclosure Policy used in discovery and remediation of vulnerabilities in Xerox software and hardware. It can be downloaded from this page: <https://www.xerox.com/information-security/information-security-articles-whitepapers/enus.html>

Additional Resources

Below are additional resources.

Security Resource	URL
Frequently Asked Security Questions	https://www.xerox.com/en-us/information-security/frequently-asked-questions
Common Criteria Certified Products	https://security.business.xerox.com/en-us/documents/common-criteria/
Current Software Release Quick Lookup Table	https://www.xerox.com/security
Bulletins, Advisories, and Security Updates	https://www.xerox.com/security
Security News Archive	https://security.business.xerox.com/en-us/news/